

System No. W-L-1327

August 2008

F Ratings — 1 and 2 Hr (See Item 1)

T Rating — 1/4 Hr
(UL/cUL)

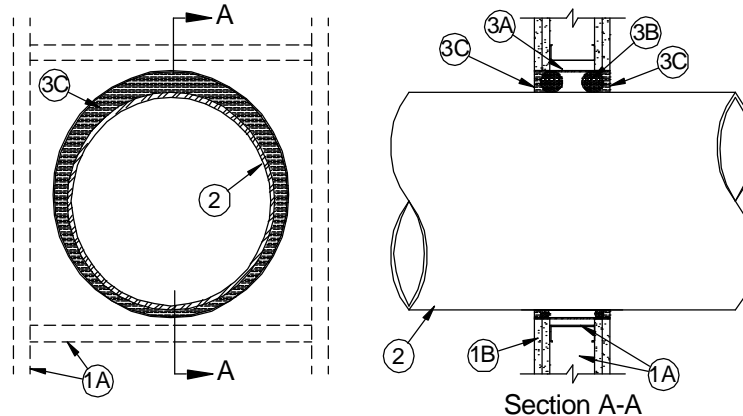

- Wall Assembly** — The 1 or 2 hr fire-rated gypsum board/steel stud wall assembly shall be constructed of the materials and in the manner described in the individual U400 or V400 Series Wall or Partition Design in the UL Fire Resistance Directory and shall include the following construction features:

- Studs** — Wall framing to consist of min 3-5/8 in. (92 mm) wide steel channel studs spaced max 24 in. (610 mm) OC. The opening shall be framed on all sides using lengths of steel runner channel and steel stud. The framing opening in the wall shall be min 2 in. (51 mm) wider and higher than the outside diam of the insulated pipe such that, when the pipe is centered in the framing opening, a min clearance of 1 in. (25 mm) is present between the pipe and the framing on all four sides.
- Gypsum Board*** — 5/8 in. (16 mm) thick, 4 ft (122 cm) wide with square or tapered edges. The gypsum board type, thickness, number of layers, fastener type and sheet orientation shall be as specified in the individual design in the UL Fire Resistance Directory. Circular cutout in wall to be min 1 in. (25 mm) larger than outside diam of through penetrant. Max diam of opening is 17 in. (432 mm).

The F Rating of the firestop system is equal to the hourly fire rating of the wall assembly in which it is installed.

- Pipe** — Nom 16 in. (406 mm) diameter (or smaller) cast iron, ductile iron or Schedule 10 (or heavier) steel pipe. One pipe to be installed either concentrically or eccentrically within the firestop system. The annular space within the firestop system shall be min 1/4 in. (6 mm) to max 3/4 in. (19 mm). Pipe to be rigidly supported on both sides of wall assembly.
- Firestop System** — The firestop system shall consist of the following:
 - Steel Sleeve** — Cylindrical sleeve fabricated from min No. 30 gauge (0.016 in. (0.4 mm)) to max No. 16 gauge (0.056 in. (1.4 mm)) thick galv steel and having a min 2 in. (51 mm) lap along the longitudinal seam. Sleeve installed by coiling the sheet steel to a diam smaller than the through openings, inserting the coil through the openings, and releasing the coil to let it uncoil against the circular cutouts in the gypsum board layers. Ends of sleeve to be flush with or recessed max 1/8 in. (3 mm) from wall surfaces.
 - Forming Material** — Foam backer rod friction-fitted into steel sleeve as a permanent form. Forming material to be recessed from both surfaces of wall as required to accommodate the required thickness of fill material.
 - Fill, Void or Cavity Material* — Caulk** — Min 1/2 in. (13 mm) thickness of fill material applied within the annulus, flush with both surfaces of wall. Edges of steel sleeve to be covered with caulk such that no gaps are present between the steel sleeve and the cutouts in the gypsum board.

TREMCO INC — TREMstop Intumescent Acrylic, FyreCaulk, or TREMstop IA+

*Bearing the UL Classification Mark



Reprinted from the Online Certifications Directory with permission from Underwriters Laboratories Inc.
Copyright © 2008 Underwriters Laboratories Inc. ®

Tremco Commercial Sealants & Waterproofing

3735 Green Road, Beachwood, OH 44122 // Phone: 216.292.5000 // 800.321.7906
220 Wicksteed Avenue, Toronto, ON M4H 1G7 // Phone: 416.421.3300 // 800.363.3213
1451 Jacobson Avenue, Ashland OH 44805 // Phone: 419.289.2050 // 800.321.6357