

System No. HW-S-0059

August 2008

Assembly Ratings — 1 and 2 Hr (See Item 2)

Joint Width — 1 In. Max

(UL/cUL)

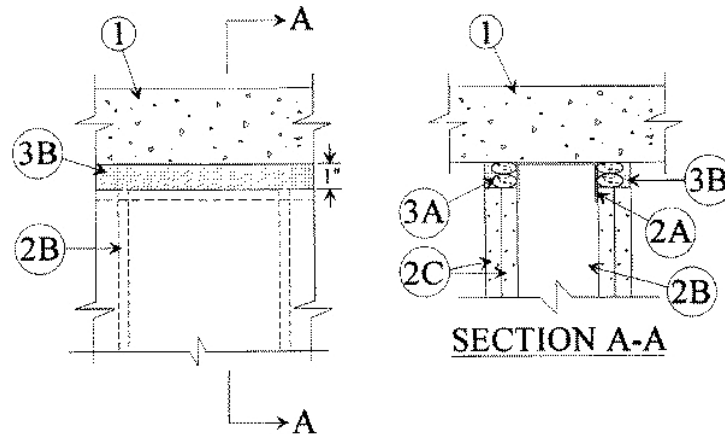

1. **Floor Assembly** — Min 4-1/2 in. (114 mm) thick reinforced lightweight or normal weight (100-150 pcf (1600-2400 kg/cu meter)) structural concrete.
2. **Wall Assembly** — The 1 or 2 h fire-rated gypsum board/steel stud wall assembly shall be constructed of the materials and in the manner described in the individual U400-Series Wall and Partition Designs in the UL Fire Resistance Directory and shall include the following construction features:
 - A. **Steel Floor and Ceiling Runners** — Floor runners of wall assembly shall consist of galv steel channels sized to accommodate steel studs (Item 2B). Ceiling runners of wall assembly shall consist of min No. 26 gauge galv steel channels sized to accommodate steel studs (Item 2B). Ceiling runners to be provided with 2 in. (51 mm) flanges. Ceiling runner secured to lower surface of floor with steel fasteners spaced max 7 in. (178 mm) OC.
 - B. **Studs** — Steel studs to be min 2-1/2 in. (64 mm) wide. Studs cut 1 in. (25 mm) less in length than assembly height with bottom nesting in and resting on floor runner and with top nesting in ceiling runner without attachment. Stud spacing not to exceed 24 in. (610 mm) OC.
 - C. **Gypsum Board*** — Gypsum board sheets installed to a min total thickness of 5/8 or 1-1/4 in. (16 or 32 mm) on each side of wall for a 1 or 2 h fire rated wall, respectively. Wall to be constructed as specified in the individual Wall and Partition Design in the UL Fire Resistance Directory, except that a max 1 in. (25 mm) gap shall be maintained between the top of the gypsum board and the lower surface of the floor. **The hourly fire rating of the joint system is equal to the hourly fire rating of the wall.**
3. **Joint System** — Max separation between bottom of floor and top of wall is 1 in. (25 mm). The joint system consists of a packing material and a fill material between the top of the wallboard and the bottom of the floor, as follows:
 - A. **Packing Material** — (Optional, Not Shown)—For 2 h rated systems, foam backer rod or mineral wool batt insulation firmly packed into the gap between the top of the gypsum board and bottom of the floor on both sides of the wall. Packing material to be recessed a min of 1/2 in. (13 mm) from both surfaces of wall.
 - B. **Fill, Void or Cavity Material*** — A min 1/2 in. (13 mm) thickness of fill material installed on each side of the wall between the top of the gypsum board and bottom of the concrete floor.

TREMCO INC — TREMstop Acrylic, TREMstop Intumescent Acrylic, Fyre-Sil, FyreCaulk, or TREMstop IA+

*Bearing the UL Classification Mark



Reprinted from the Online Certifications Directory with permission from Underwriters Laboratories Inc.
Copyright © 2008 Underwriters Laboratories Inc. ®