

PERFORMANCE TEST REPORT

Rendered to:

TREMCO INC.

SERIES/MODEL: Proglaze ETA - System 3

PRODUCT TYPE: Pre-Engineered Air Barrier Transition Assembly

Title	Summary of Results
Air Infiltration	<0.01 cfm/ft ²
Static Water Resistance Test Pressure	15.0 psf
Dynamic Water Resistance Test (115 mph)	34.6 psf
Uniform Load Deflection Test Pressure	±100.0 psf
Uniform Load Structural Test Pressure	±150.0 psf

Reference should be made to Architectural Testing, Inc. Report No. 92938.01-109-44 for complete test specimen description and data.

PERFORMANCE TEST REPORT

Rendered to:

TREMCO INC.
1451 Jacobson Avenue
Asland, Ohio 44805

Report No.: 92938.01-109-44
Revision 1: 08/21/09
Test Date: 07/09/09
Report Date: 07/23/09
Expiration Date: 07/09/13

Project Summary: Architectural Testing, Inc. was contracted by Tremco Inc. to perform testing on a Series/Model Proglaze ETA - System 3, pre-engineered air barrier transition assembly. Test specimen description and results are reported herein. The sample was provided by the client.

Test Methods: The test specimen was evaluated in accordance with the following:

ASTM E 283-04, Test Method for Determining Rate of Airflow Through Exterior Windows, Curtain Walls and Doors Under Specified Pressure Differences Across the Specimen.

ASTM E 330-02, Test Method for Structural Performance of Exterior Windows, Curtain Walls and Doors by Uniform Static Air Pressure Difference.

ASTM E 331-00, Test Method for Water Penetration of Exterior Windows, Curtain Walls and Doors by Uniform Static Air Pressure Difference.

AAMA 501.1-05, Standard Test Method for Water Penetration of Windows, Curtain Walls and Doors Using Dynamic Pressure.

AAMA 501.4-00, Recommended Static Test Method for Evaluating Curtain Wall and Storefront Systems Subjected to Seismic and Wind Induced Interstory Drifts.

Test Specimen Description:

Series/Model: Proglaze ETA - System 3

Product Type: Pre-Engineered Air Barrier Transition Assembly manufactured from a translucent 40 durometer dense silicone compound

Test Specimen Description: (Continued)

Rough Opening Overall Size: 1' 10" wide by 1' 6" high

Window Overall Size: 1' 4" wide by 1' 4" high

Fixed Daylight Opening Size: 1' 0-3/8" wide by 1' 0-3/4" high

Overall Area: 1.78 ft²

Finish: The frame members were clear anodized aluminum.

Glazing Details: The infill panel utilized a 1/2" thick acrylic sheet. The acrylic sheet was positioned in the glazing pocket using Tremco's SGT-922 foam tape that was applied at the interior sightline and a continuous "L" shaped structural silicone tensile bead was applied using Proglaze SSG silicone sealant. Pressure plates were secured at each side using four screws.

Weatherstripping: No weatherstrip was utilized.

Frame Construction: The frame was constructed of extruded aluminum with butted corners.

Hardware: No hardware was utilized.

Drainage: No drainage was utilized.

Reinforcement: No reinforcement was utilized.

Installation: The buck was constructed using 2x6 wood studs secured at each end with screws. The buck was then sheathed using a sheet of 3/4" plywood. The window unit was constructed using Kawneer's 1600 Wall System (1) Pressure Bar System and was installed into the buck, utilizing a 3" gap between the frame and rough opening. The window was secured at the head and sill utilizing a slotted full length steel mounting bracket that was secured to the window frame with three 3/8" diameter bolts with washers and nuts. The head and sill were secured to the buck with steel angles, located at each end of the window. The angles were secured to the buck with two 3/8" x 3" lag screws and secured to the mounting angle with one 3/8" diameter bolt with washer and nut. The steel anglers utilized a slot to allow horizontal movement of 2" from side to side. The jambs were secured 5-1/2" from each end using a 1/2" diameter threaded steel rod. One end of the rod was secured to the window frame using a flat washer, a lock washer, and a nut. The opposite end was secured to the buck through a hole in the wood stud and an aluminum plate, with 2-1/2" of the rod extended past the stud and then secured using a flat washer, a lock washer, and a nut.

Test Specimen Description: (Continued)

Installation (Continued): The exterior wood surfaces around the window unit were coated with ExoAir primer and then covered with Tremco ExoAir 110 membrane. The exterior perimeter of the window frame was sealed using Tremco's Proglaze ETA - System 3, pre-engineered air barrier transition assembly. The system utilized an 8" wide silicone extrusion, which was inserted into mullion race filled with Spectrem 1 silicone sealant. The system has pre-molded corners, which overlapped 1-1/2" to 2" at each end with a 10" cut length of extruded silicone material. The silicone gasket's perimeter edge was secured to the ExoAir 110 membrane covering the wood buck using a 1-1/2" to 2" wide bead of Spectrem 1 sealant. An additional bead of Spectrem 1 sealant was used around the perimeter of the membrane and the window frame.

Test Results: The temperature during testing was 75°F. The results are tabulated as follows:

<u>Test Method</u>	<u>Title of Test</u>	<u>Results</u>
ASTM E 283	Air Infiltration (Before Rack Test) (Complete Window Assembly) 1.60 psf (25 mph) 6.27 psf (50 mph)	0.01 cfm/ft ² 0.01 cfm/ft ²
ASTM E 283	Air Infiltration (Before Rack Test) (ExoAir 110 Proglaze ETA assembly) 1.60 psf (25 mph) 6.27 psf (50 mph)	<0.01 cfm/ft ² <0.01 cfm/ft ²
ASTM E 331	Water Resistance (Before Rack Test) 15.04 psf	No leakage
AAMA 501.1	Dynamic Water Resistance (Before Rack Test) 115 mph (34.6 psf)	No leakage
AAMA 501.4 (Modified)	Rack Test (Shift window unit 2" in both directions) Three cycles	No damage
ASTM E 283	Air Infiltration (After Rack Test) (Complete Window Assembly) 1.60 psf (25 mph) 6.27 psf (50 mph)	0.05 cfm/ft ² 0.07 cfm/ft ²
ASTM E 283	Air Infiltration (Before Rack Test) (ExoAir 110 Proglaze ETA assembly) 1.60 psf (25 mph) 6.27 psf (50 mph)	<0.01 cfm/ft ² <0.01 cfm/ft ²

Test Results: (Continued)

<u>Test Method</u>	<u>Title of Test</u>	<u>Results</u>
ASTM E 331	Water Resistance (After Rack Test) 15.04 psf	No leakage
AAMA 501.1	Dynamic Water Resistance (After Rack Test) 115 mph (34.6 psf)	No leakage
ASTM E 330	Uniform Load Deflection (Loads were held for 10 seconds) 100.0 psf (positive) 100.0 psf (negative)	No damage No damage
ASTM E 330	Uniform Load Structural (Loads were held for 10 seconds) 150.0 psf (positive) 150.0 psf (negative)	No damage No damage

Note: The system passed +175 psf load, but after 9 seconds at -175 psf the lower left molded corner (viewing from the outside) of the window unit ripped open.

General Note: All testing was performed in accordance with the referenced standards.

Tape and film were not used to seal against air leakage during structural testing.

Drawing Reference: The test specimen drawings have been reviewed by Architectural Testing and are representative of the test specimen reported herein.

List of Official Observers:

<u>Name</u>	<u>Company</u>
Peter Poirier	Tremco Inc.
Jim Holler	Tremco Inc.
Ed Retzbach	Tremco Inc.
Timothy J. McGill	Architectural Testing, Inc.
Michael D. Stremmel, P.E.	Architectural Testing, Inc.
Scott Gill	Architectural Testing, Inc.

Detailed drawings, data sheets, representative samples of test specimens, a copy of this report, or other pertinent project documentation will be retained by Architectural Testing, Inc. for a period of four years from the original test date. At the end of this retention period, such materials shall be discarded without notice and the service life of this report will expire.

Results obtained are tested values and were secured by using the designated test methods. If test specimen contains glazing, no conclusions of any kind regarding the adequacy or inadequacy of the glass in the test specimen can be made. This report does not constitute certification of this product nor an opinion or endorsement by this laboratory. It is the exclusive property of the client so named herein and relates only to the specimen(s) tested. This report may not be reproduced, except in full, without the written approval of Architectural Testing, Inc.

For ARCHITECTURAL TESTING, INC:

Scott Gill
Senior Technician

Michael D. Stremmel, P.E.
Senior Project Engineer

SG:vlm

Attachments (pages): This report is complete only when all attachments listed are included.

- Appendix-A: Test Equipment (1)
- Appendix-B: Photographs (3)
- Appendix-C: Drawings (5)

Revision Log

<u>Rev. #</u>	<u>Date</u>	<u>Page(s)</u>	<u>Revision(s)</u>
0	07/23/09	N/A	Original report issue
1	08/21/09	Summary Page, Page 1	Changed Product Type to Pre-Engineered Air Barrier Connection from Expansion Joint Material
		Page 2 and 3	Glazing Details and Installation Paragraphs, Changed verbiage in both
		Page 3	Added Air Infiltration Results for ExoAir 110 Proglaze ETA assembly
		Page 4	Test Results Note - Added verbiage to note

Appendix A
Test Equipment

Instrument	Manufacturer	Asset #
Control panel	Architectural Testing, Inc.	005289
Water spray rack (stand up)	Architectural Testing, Inc.	
84" diameter wind generator	Architectural Testing, Inc.	
Control panel	Architectural Testing, Inc.	003232

Appendix B

Photographs



**Photo No. 1
Specimen Set-up**



**Photo No. 2
Water Penetration Set-up**



Photo No. 3
Dynamic Water Penetration Set-up



Photo No. 4
Structural Load Set-up



Photo No. 5
Failure of Membrane During -175 psf Structural Load

Appendix C

Drawings

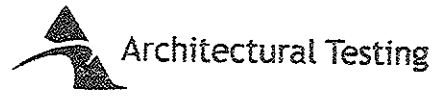
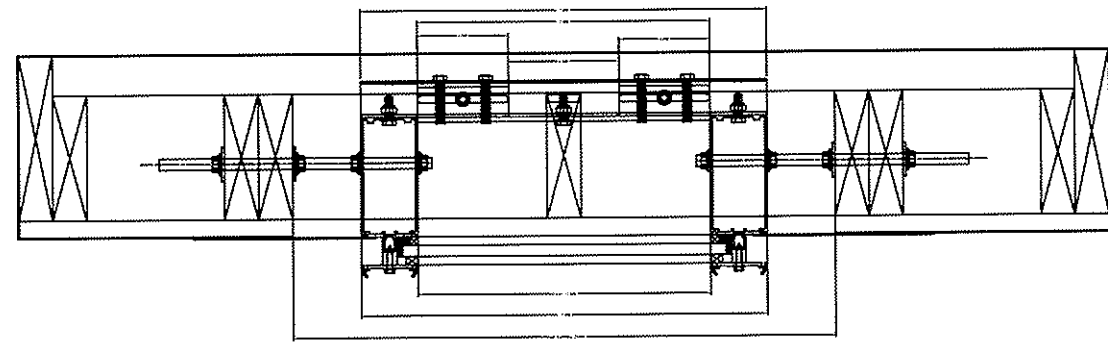
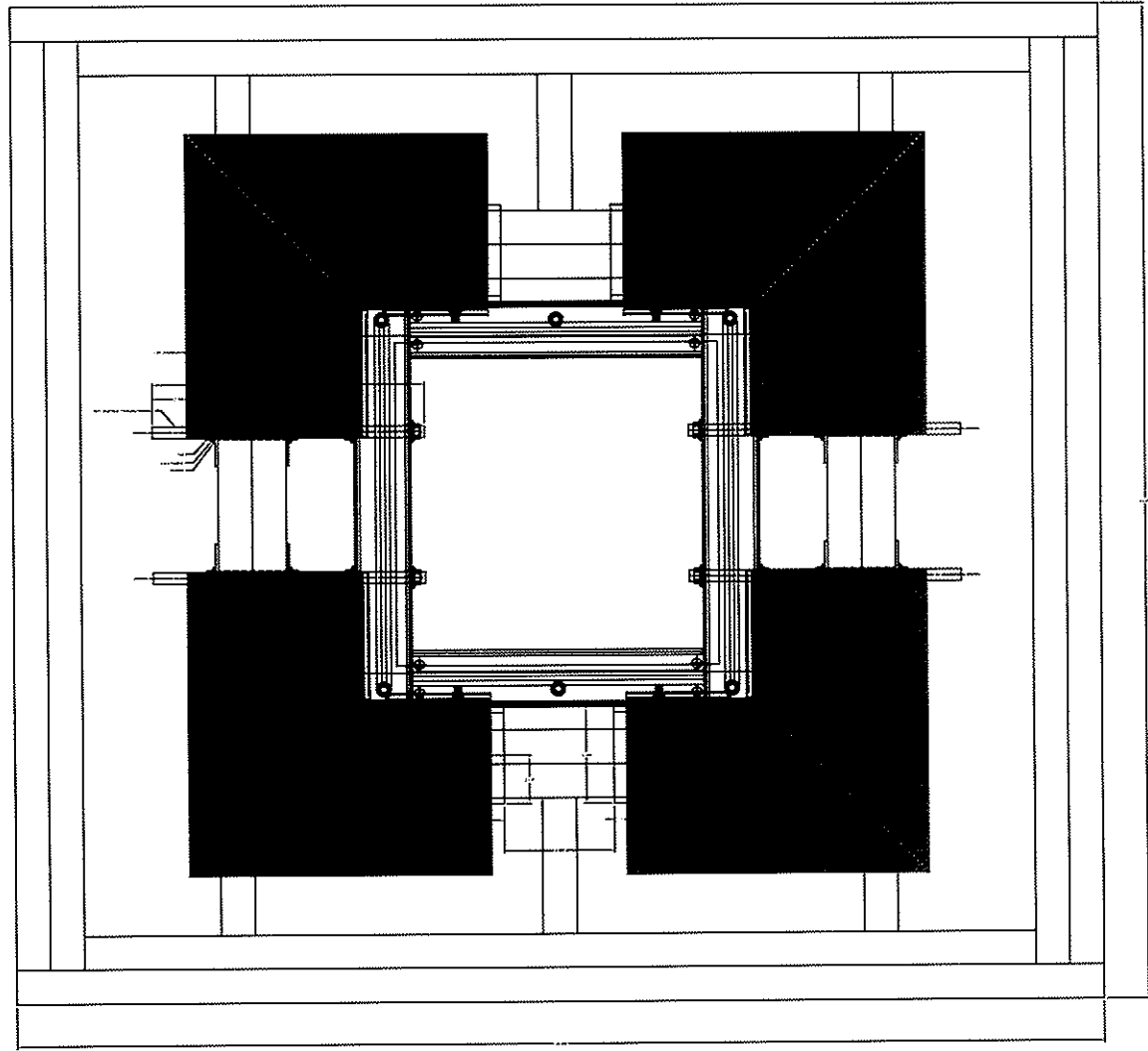
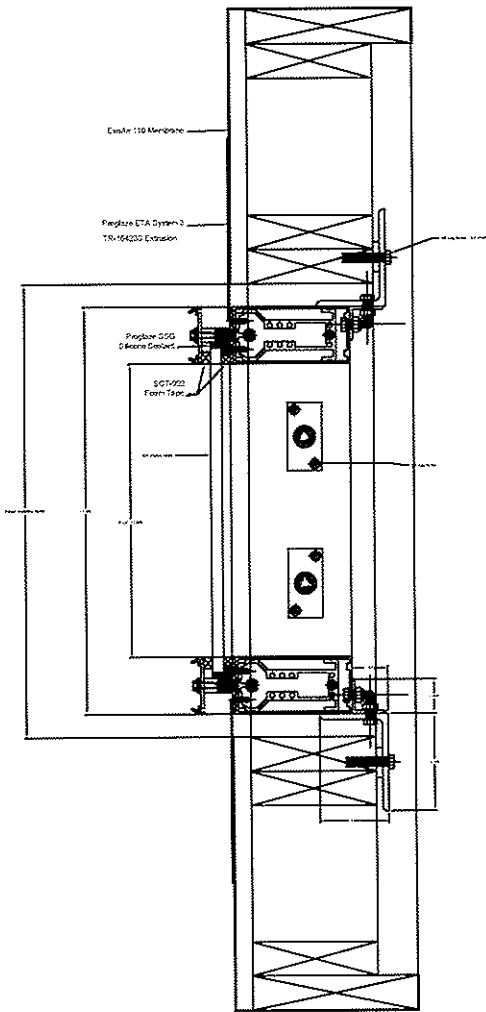

Test sample complies with these details.
 Deviations are noted.

Report# 92935.01-109-44
 Date 07/23/09 Tech S.G. Kim



Architectural Testing

Test sample complies with these details.
Deviations are noted.

Report# 92938.01-109-44

Date 07/23/09 Tech S.G. [unclear]

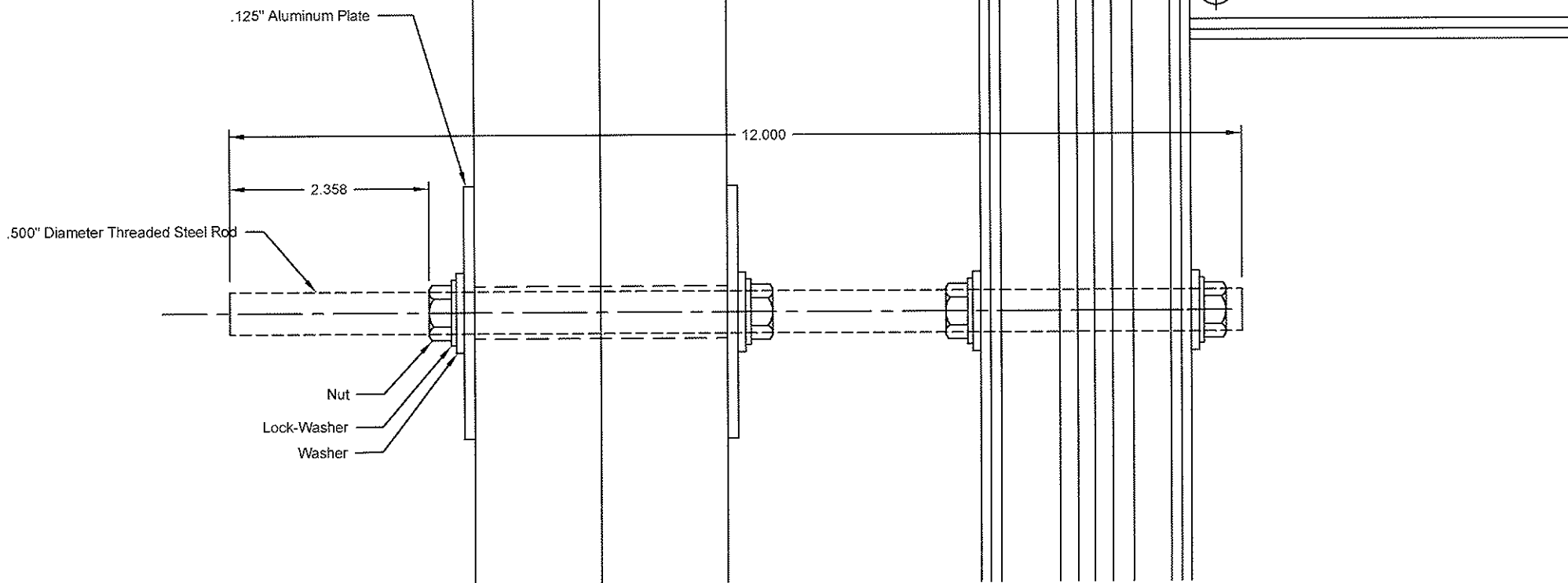



Architectural Testing

Test sample complies with these details.
Deviations are noted.

Report# 92935.01-109-44

Date 07/23/09 Tech SGM

ExoAir 110 Membrane

Proglaze ETA System 3

TR-16423S Extrusion

3/8" Lag Screw - 3-4" Shaft

Proglaze SSG
Silicone Sealant

SGT-922
Foam Tape

.500" Plastic Sheet

1/4" Lag Screw

Rough Opening 19.860

17.860

D.L.O. 12.860

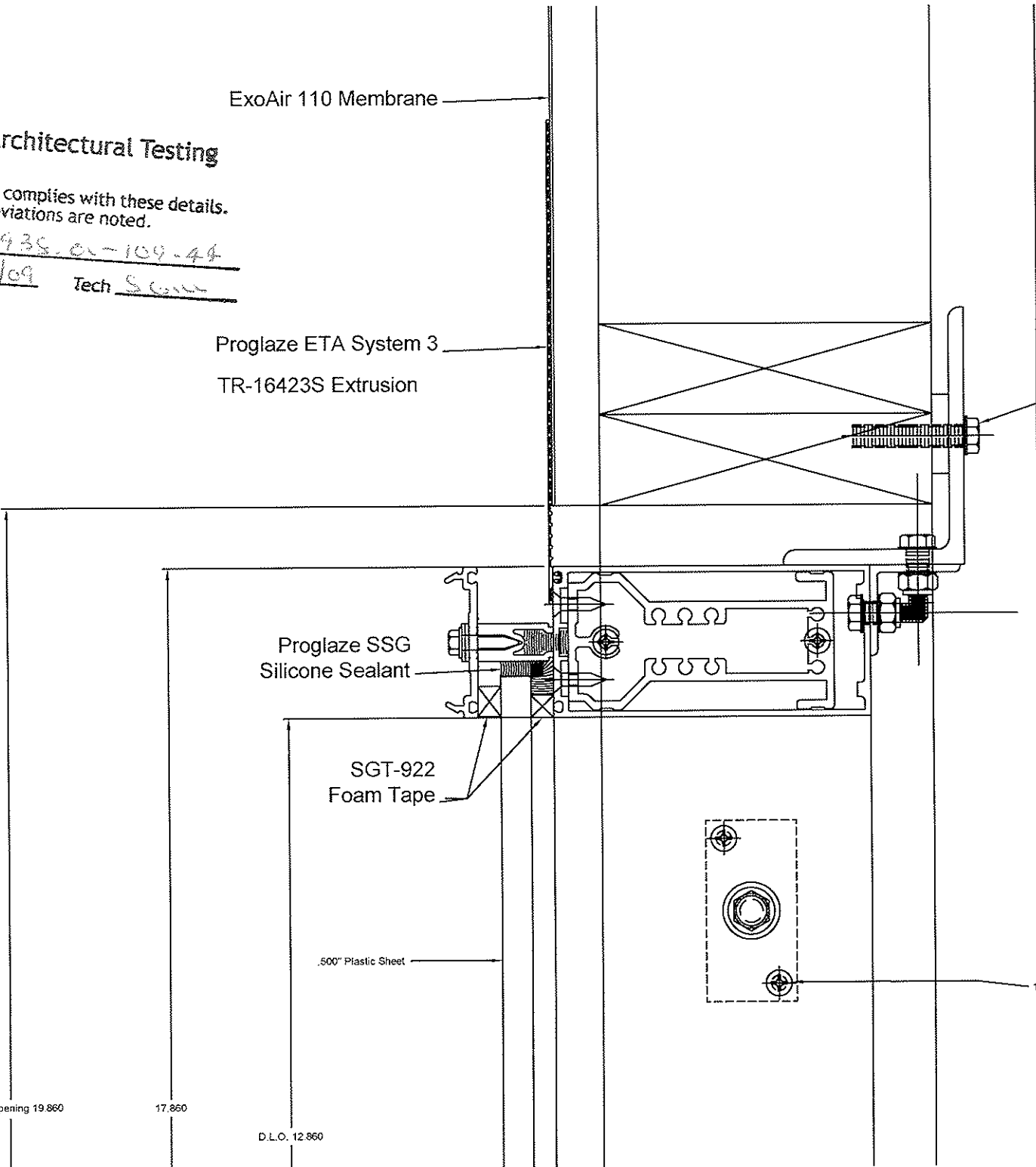



Architectural Testing

Test sample complies with these details.
Deviations are noted.

Report# 92935.01-109-44

Date 07/23/09 Tech S.G.H.

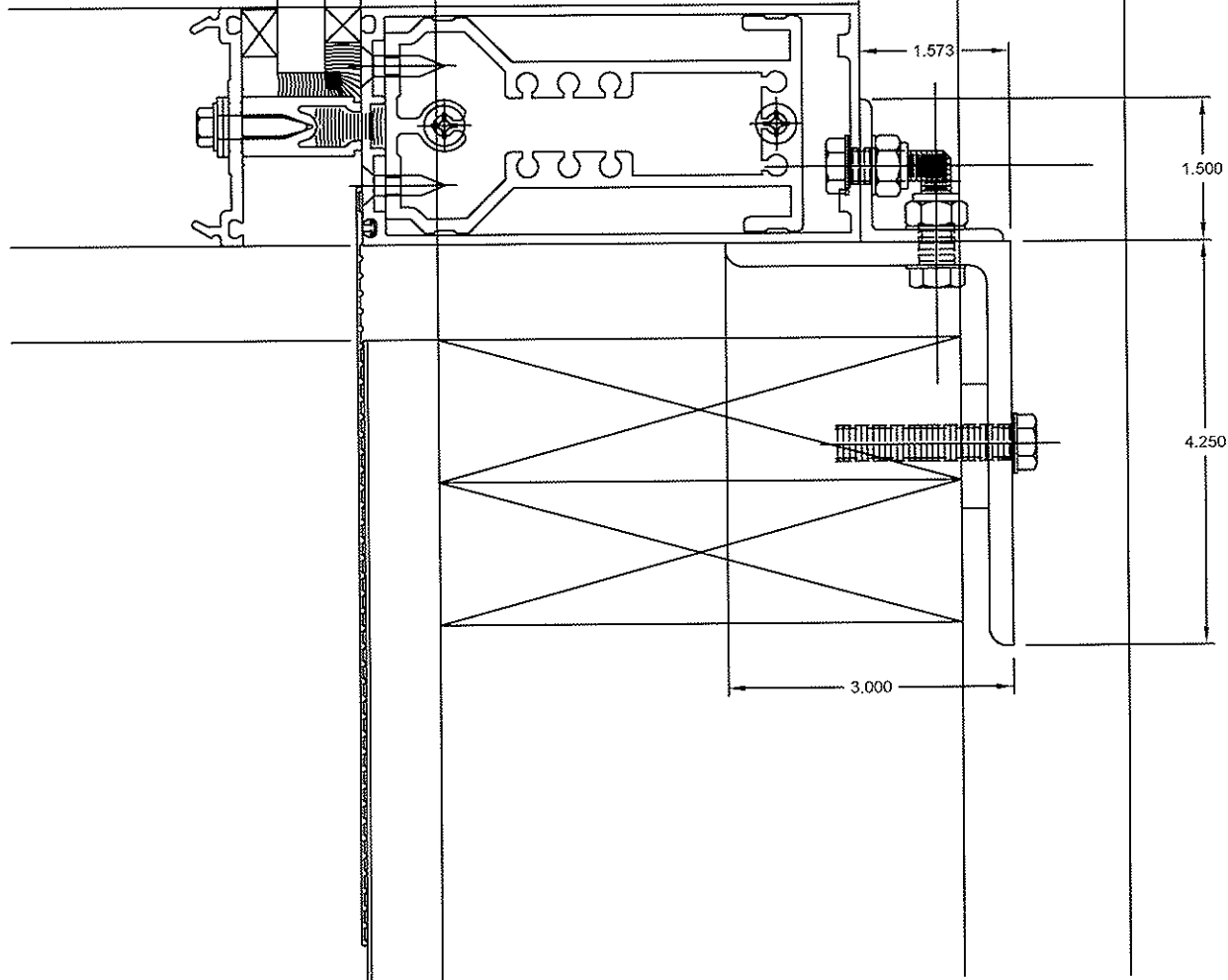
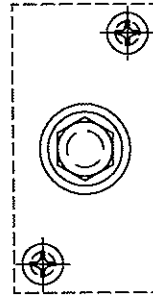

Test sample complies with these details.
Deviations are noted.

Report# 92935.01-109-44

Date 07/23/09 Tech S. Gilman

