

SGT-900 Series Structural Glazing Tapes

Product Description

Tremco SGT-900 Series Structural Glazing Tapes are open cell high density polyurethane foam tapes with a micro-cellular structure.

Basic Uses

Tremco SGT-900 Series Structural Glazing Tapes have been specifically developed to be utilized as a compatible spacer for Structural Glazing Systems.

Tremco requires review of project details and adhesion/compatibility testing of all structural components. Drawings and samples should be forwarded to Tremco Technical Services for approval prior to initiation of work.

Packaging

Tremco SGT-900 Series Structural Glazing Tapes are supplied on rolls packaged in cartons. The length of the rolls and number of rolls in a carton depend on the thickness and width of the foam tape.

Available thickness:

- 1/8" (3.18 mm)
- 3/16" (4.76 mm)
- 1/4" (6.35 mm)
- 5/16" (7.93 mm)
- 3/8" (9.52 mm)
- 1/2" (12.70 mm)*

*Not available in SGT-922

INSTALLATION

To assure that the proper adhesive properties are achieved, it is necessary to clean the mounting surfaces with a clean rag saturated with an approved solvent, such as, but not limited to Methyl Ethyl Ketone (MEK) and/or Isopropyl Alcohol (IPA). Do not allow solvent to air dry. Immediately follow the solvent wipe with a dry wipe with a clean cloth.

Caution must be exercised in the tape placement as once the adhesive contacts the mounting surface, it becomes difficult to adjust or remove.

For structural silicone glazing, the standard minimum joint configuration is 1/4" x 1/4" (6.35 mm x 6.35 mm). However, there may be applications where a thinner tape may be used in conventional glazing applications. The tape width can not be less than the tape thickness and the minimum width is 1/4" (6.35 mm).

Tremco's SGT tapes are available with adhesive on two sides. Tape with adhesive on one side is available on request. This product should not be used in place of temporary fasteners.

Availability/Cost

Tremco SGT-900 Series Structural Glazing Tapes are available in a wide variety of sizes with pressure sensitive adhesive on one side or opposite surfaces and is supplied with a protective release liner covering the adhesive coated surfaces. Cost may

TYPICAL PHYSICAL PROPERTIES

Properties	Test Method	921	922
Color		Black	Black
Density (lbs./cu. ft.)	ASTM D 1667	31	22
Hardness (Shore A)	ASTM D 2240	35	30
Tensile Strength (psi)	ASTM D 412	180	130
Force to Compress 10% (psi)	ASTM D 1667	31	16
Ultimate Elongation (%)	ASTM D 412	125	105
Thermal Conductivity (BTU (in.) Sq. Ft. (Hr.) °F)	ASTM C 518	.55	.55
Adhesive Properties			
Dynamic Tensile (psi)	*TRS-ST/839	55	45
Dynamic Shear (psi)	*TRS-ST/840	40	30
*Tremco Research Standard - Standard Test			
Application Temp.	40 - 125°F (4 - 52°C)		
Service Temp.	-40 - 180°F (-40 - 82°C)		

be obtained from your local Tremco representative, or by contacting our Customer Service Department in Ashland, Ohio, at 800-321-6357 or Tremco Canada at 800-363-3213.

Precautions

User should refer to product labels and Material Safety Data Sheets for information on safe use and storage.

Limitations

Tremco SGT-900 Series Structural Glazing Tape adhesive properties of the coating must not be used as part of the structural silicone surface contact calculations, or as temporary retainers. Tremco SGT-900 Series Structural Glazing Tapes are not intended for use as the primary seal in conventional glazing systems.

Warranty

Tremco warrants their products to be free of defects. Under this warranty Tremco will provide, at no charge, product in containers to replace any product proven to be defective when applied, tested and cured (if applicable) in accordance with Tremco's written instructions, standards and applications recommended by Tremco as suitable for this product.

User shall determine suitability of the product for their intended use and assume all risk and liability therewith. Seller shall not be liable for any injury, loss or damage, direct or consequential, arising out of the use of the product. All claims concerning product defects must be made within 6 months of shipment. Absence of such claims in writing, during this period, will constitute a waiver of all claims with respect to such product.

This warranty is the user's sole remedy and is IN LIEU OF any and all other warranties, expressed or implied, including but not limited to, any implied warranty of MERCHANTABILITY OR FITNESS FOR A PARTICULAR PURPOSE.

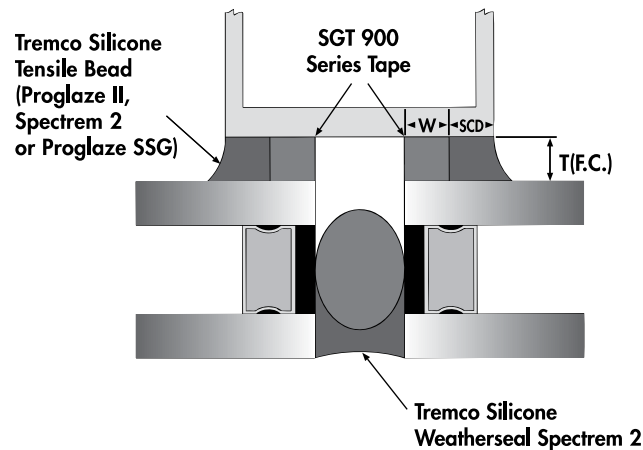

T = Sealant/Tape Thickness 1/4" min. (6.35mm)
SCD = Surface Contact Depth 1/4" min. (6.35mm)
W = Width of Tape (Adhesive side)



Tremco Commercial Sealants & Waterproofing

3735 Green Road, Beachwood, OH 44122 // Phone: 216.292.5000 // 800.321.7906
220 Wicksteed Avenue, Toronto, ON M4H 1G7 // Phone: 416.421.3300 // 800.363.3213
1451 Jacobson Avenue, Ashland OH 44805 // Phone: 419.289.2050 // 800.321.6357