

Proglaze ETA Patent Pending

System 3 – Pressure Bar System

- **System Includes:**
 - Silicone Rubber Extrusion: Extruded, 40 durometer, translucent silicone, with lock-in dart.
 - Silicone Rubber Corner: 40 durometer, translucent silicone with lock-in dart, supplied in left and right-hand mates.

Extrusion Die TR-16423S

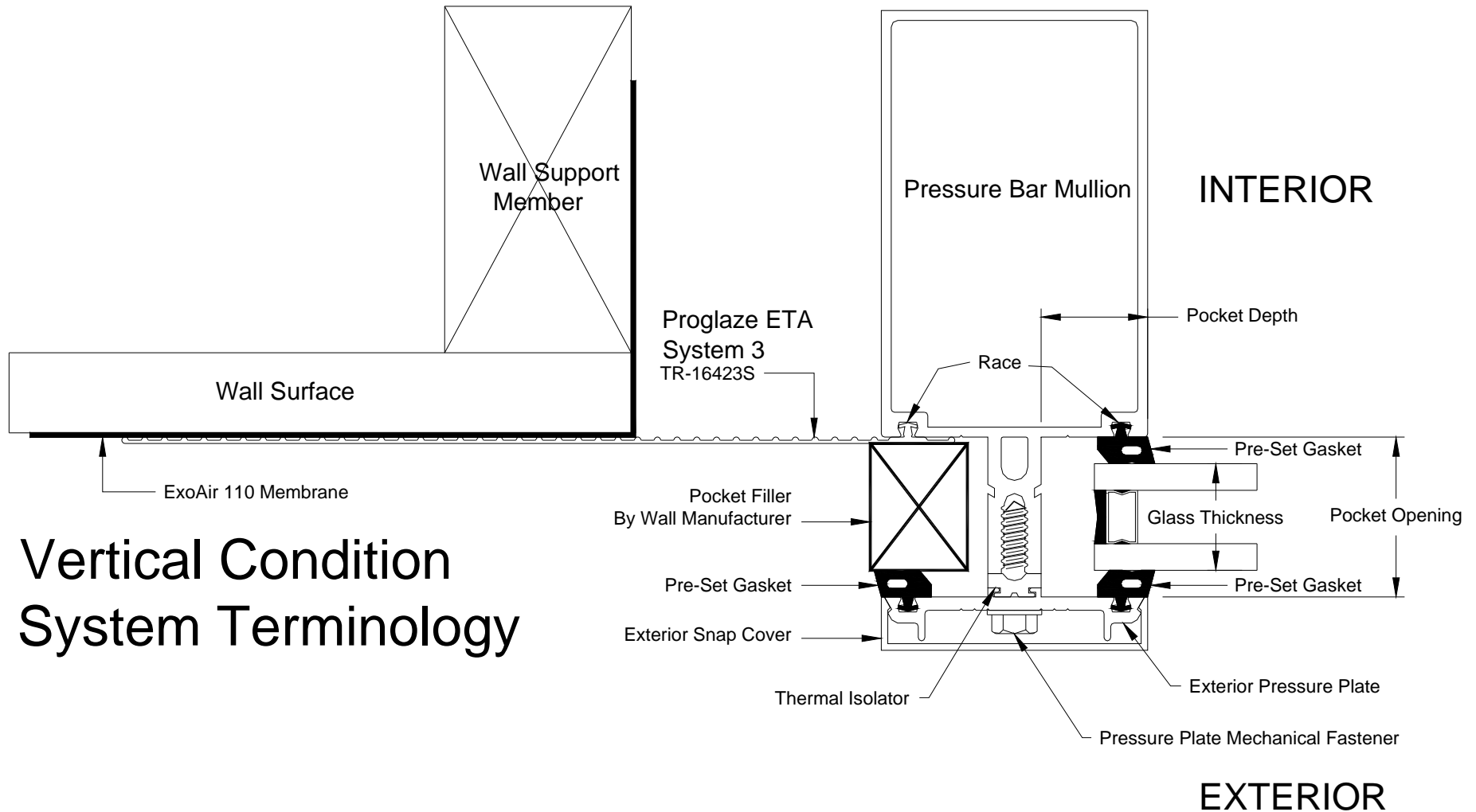

This dart design will work in a majority if not all pressure bar race conditions, while allowing the gasket to still work in various metal race centerlines.

Proglaze[®] ETA PATENT PENDING
System 3 – Pressure Bar System

TREMCO

Extrusion Die TR-16423S

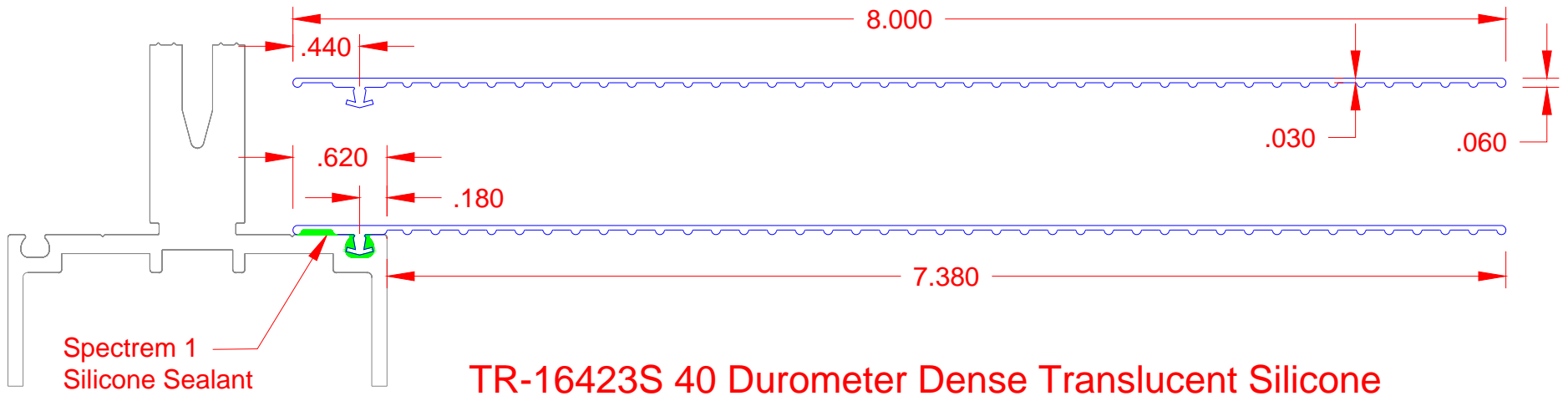

Proglaze[®] ETA PATENT
PENDING
System 3 – Pressure Bar System

TREMCO

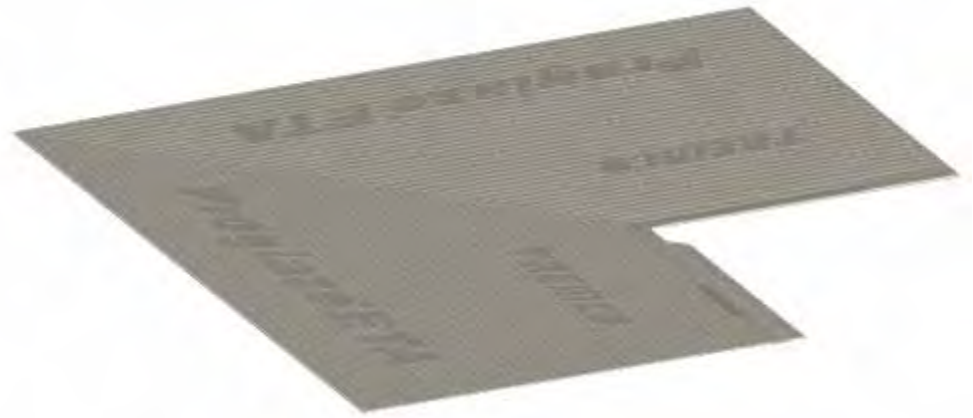
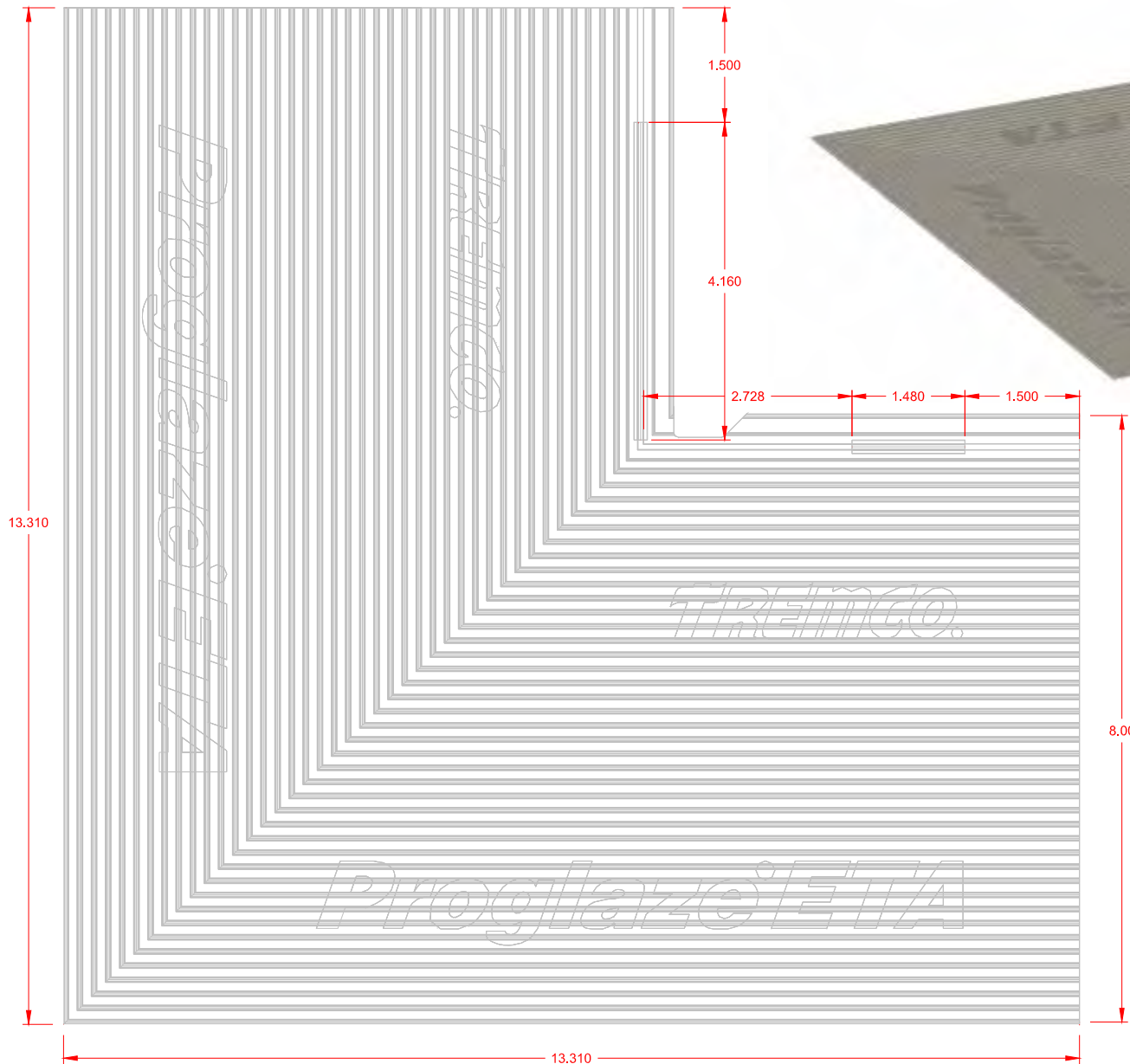

Molded Corner
TR-16448S

Proglaze[®] ETA PATENT PENDING
System 3 – Pressure Bar System



Typical Pressure Bar System

Consult wall manufacturer on proper milling/notching of the mullion stem to allow placement of the Proglaze ETA Molded Corner and sealant.

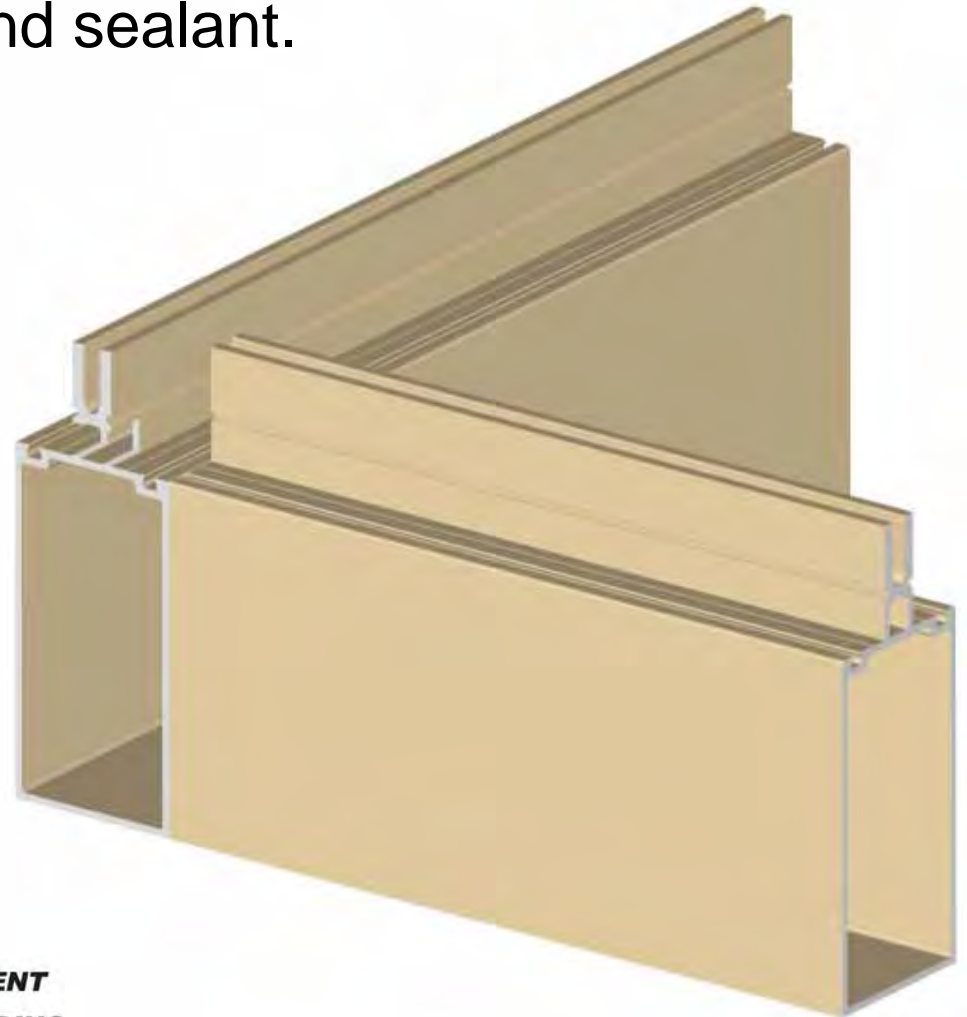

Proglaze[®] ***ETA*** PATENT
PENDING
System 3 – Pressure Bar System

TREMCO

Each wall system will utilize a joint plug to seal the metal joinery and compartmentalize the opening. Follow wall manufacturer's installation and sealing procedures.

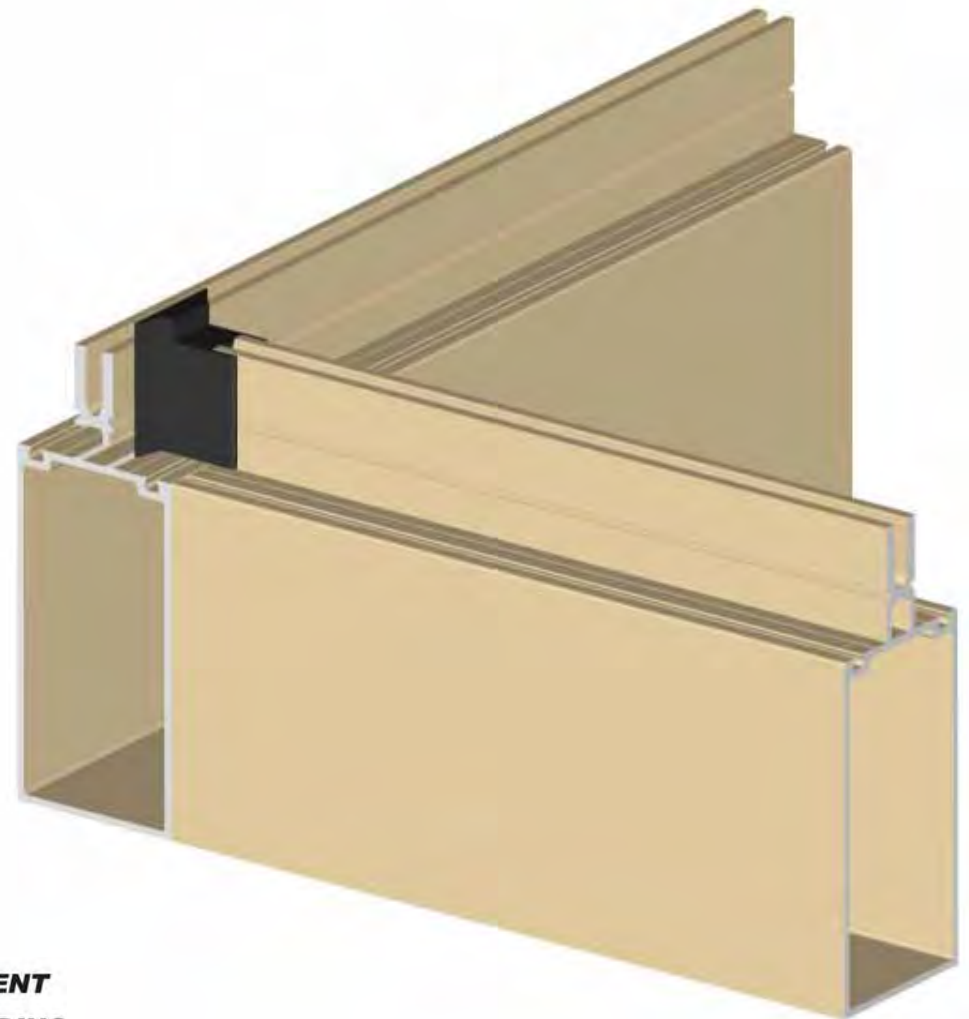

Proglaze[®] ETA PATENT
PENDING
System 3 – Pressure Bar System

TREMCO

A continuous bead of Spectrem 1 silicone sealant is applied in and around the mullion race.

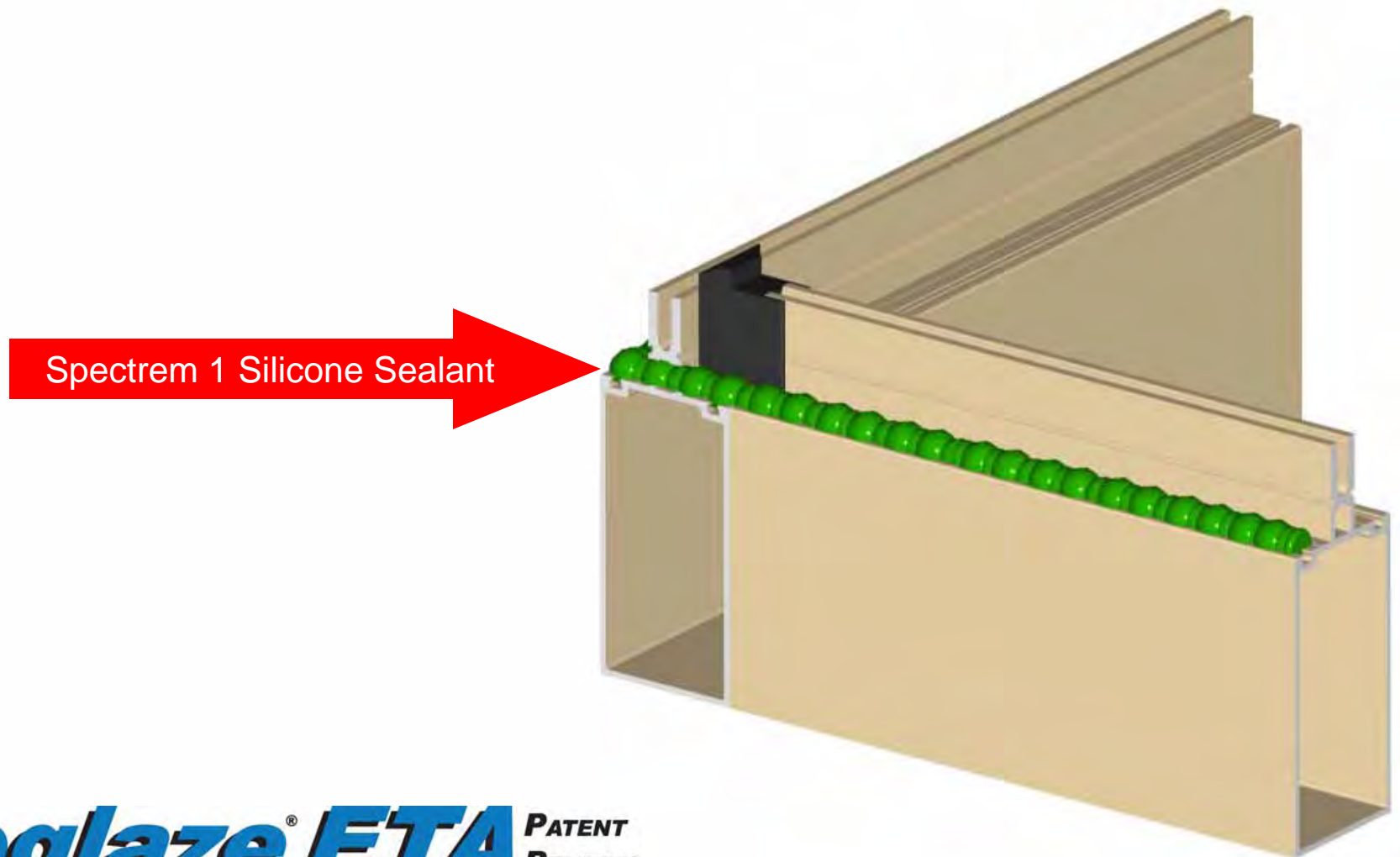

Proglaze® ***ETA*** PATENT
PENDING
System 3 – Pressure Bar System

TREMCO®

Pre-cut lengths of TR-16423S can be inserted into the race.
Placement is typically 5 inches from the metal corner.

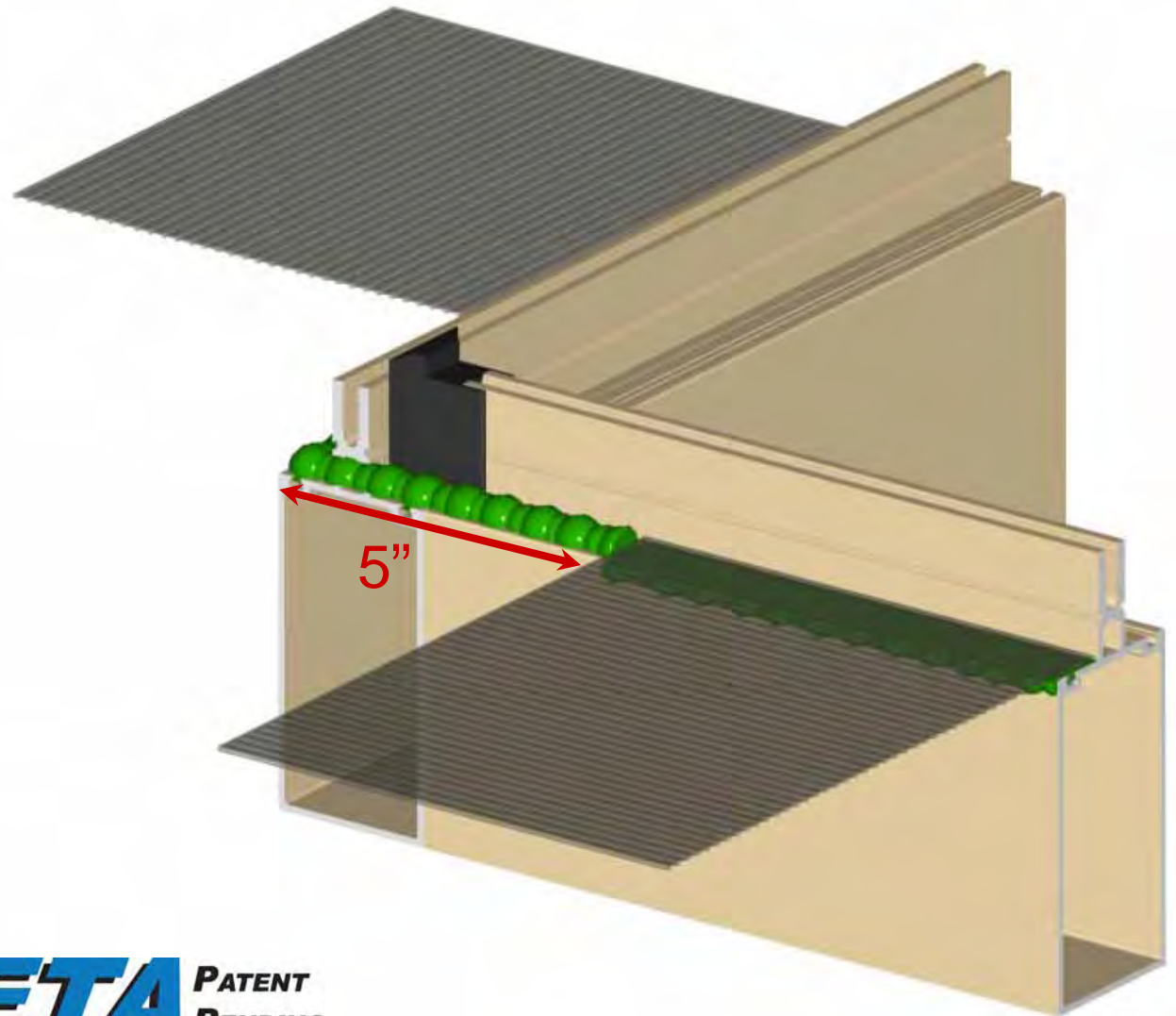

Proglaze[®] ETA PATENT
PENDING
System 3 – Pressure Bar System

TREMCO

A bead of Spectrem 1 is applied over the edges of TR-16423S to make a lap joint with the molded corner TR-16448S.

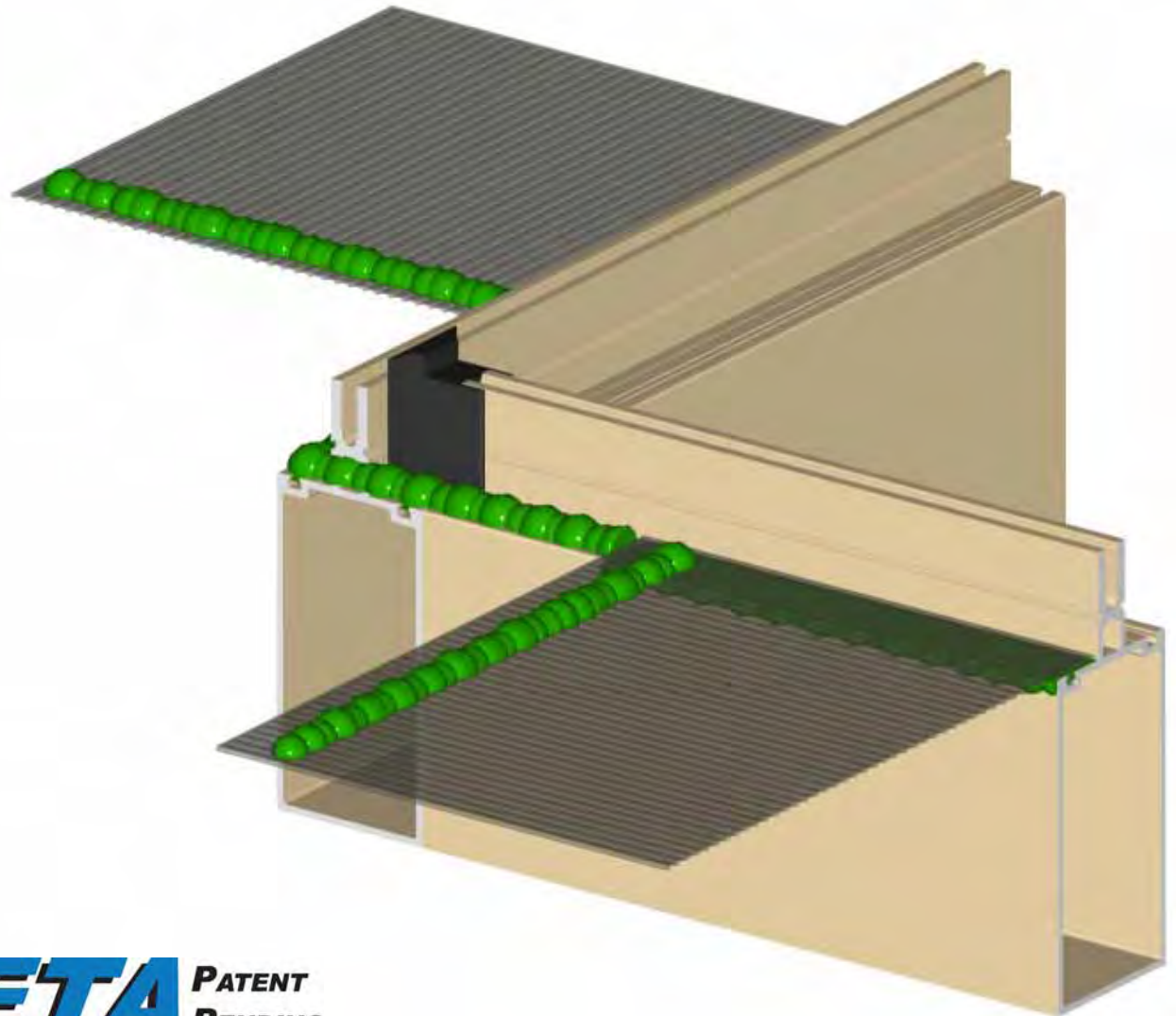

Proglaze® ***ETA*** PATENT
PENDING
System 3 – Pressure Bar System

TREMCO

The molded corner will require left and right handed designs to eliminate the need for the installer to hand trim the dart.

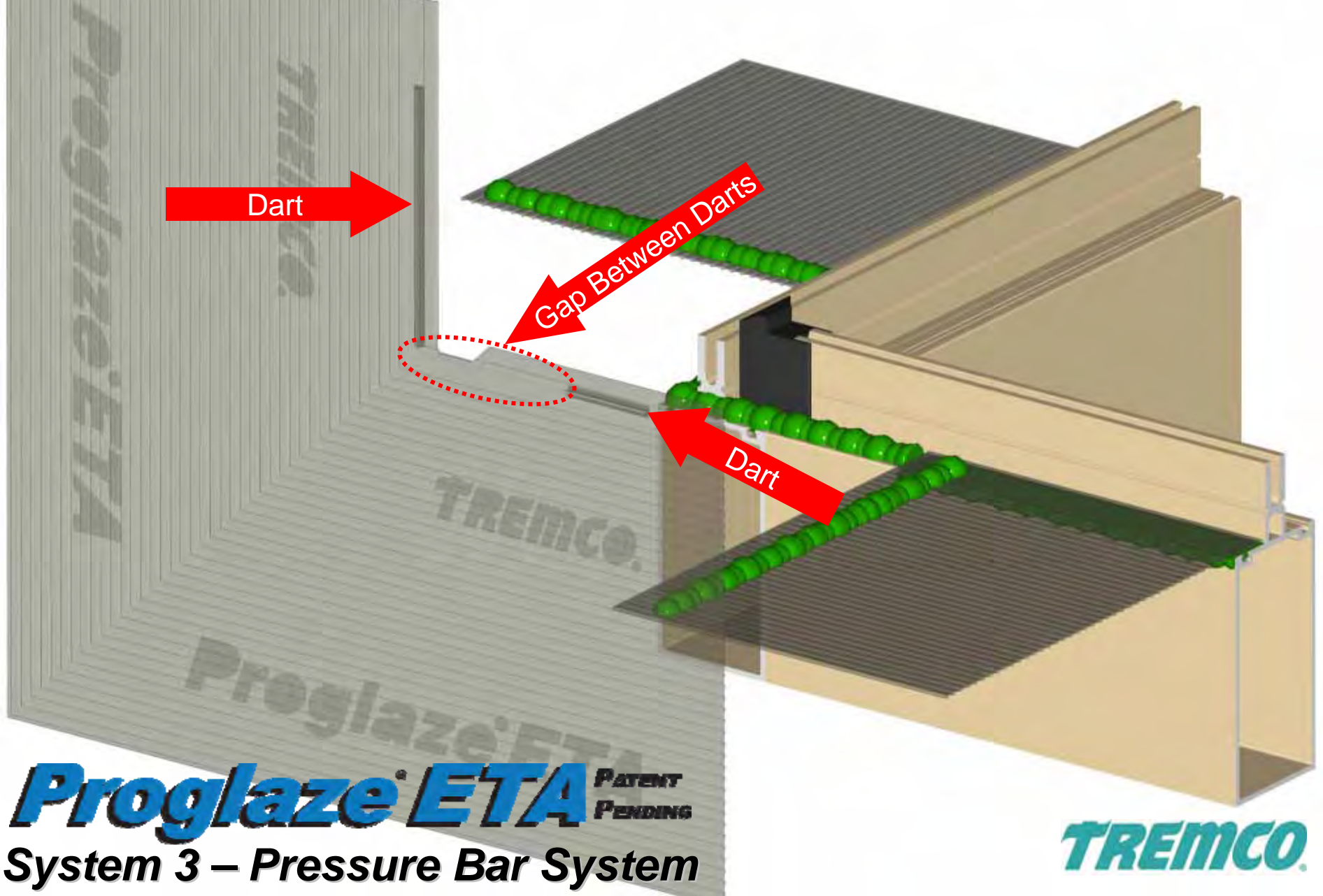

The corner is positioned and embedded into the sealant locking the darts into the mullion race.

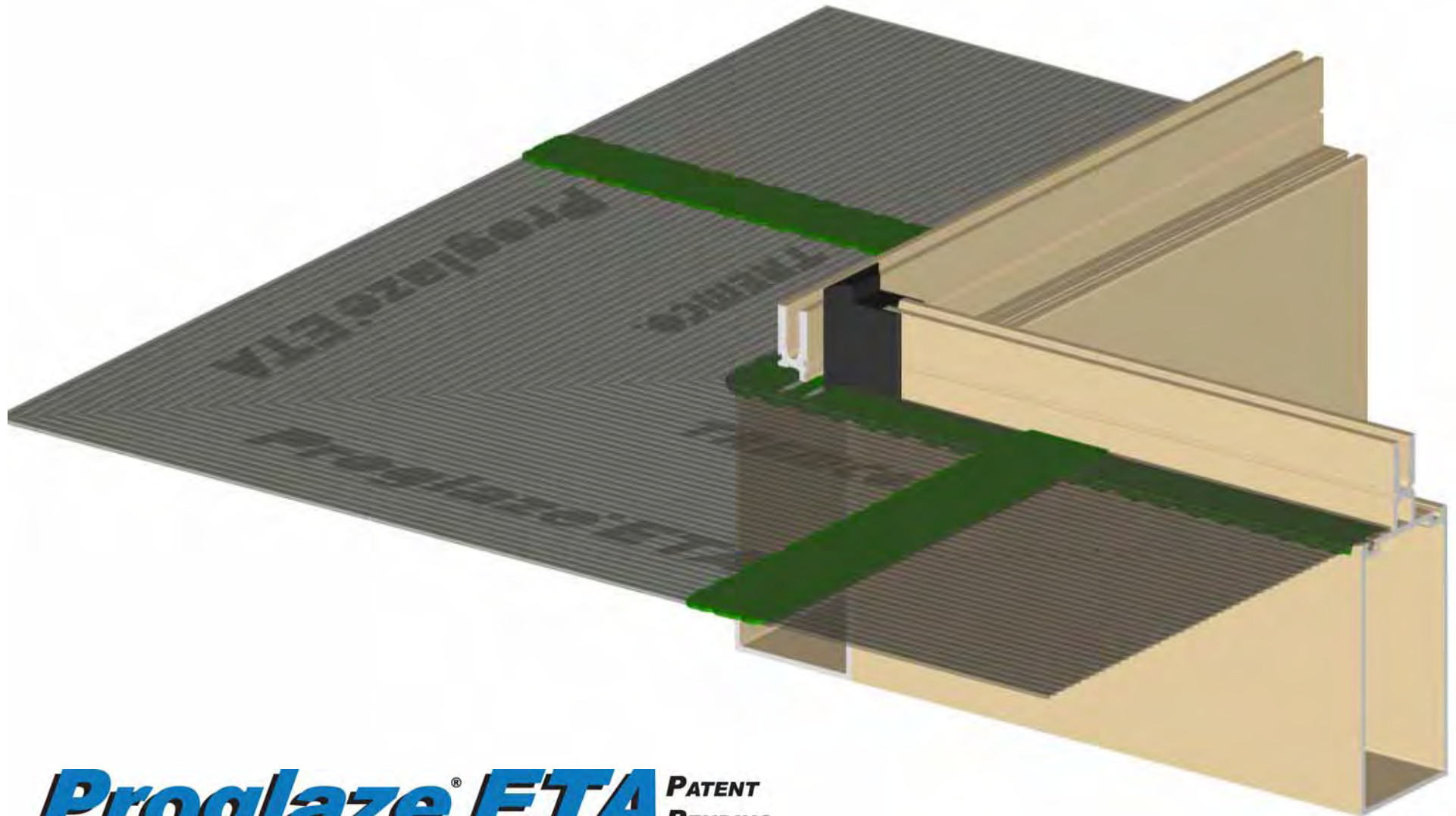

Proglaze[®] ETA PATENT
PENDING
System 3 – Pressure Bar System

TREMCO

Once these connections are made the glazing gaskets and glass installation can be started.

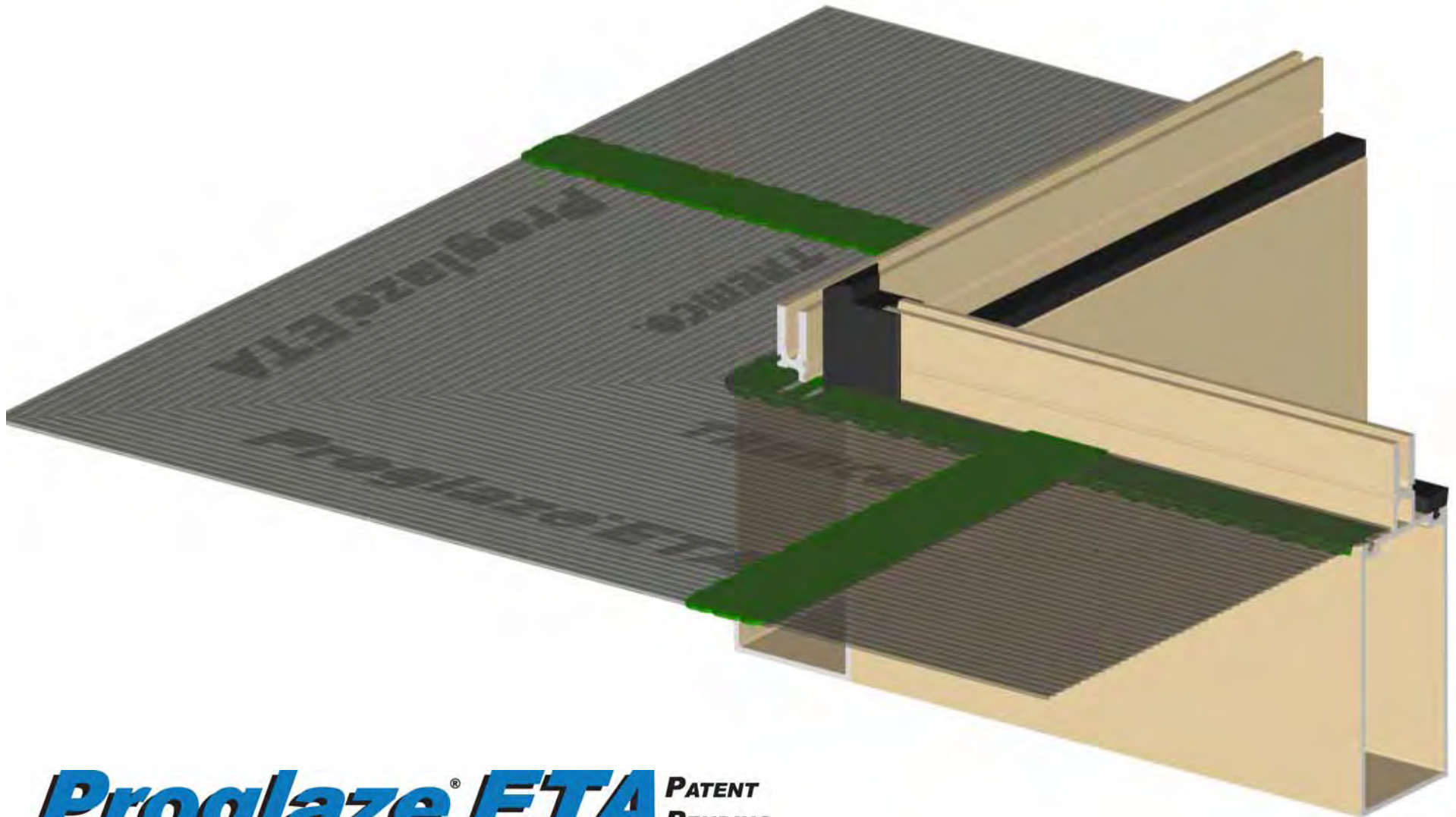

Proglaze[®] ETA PATENT
PENDING
System 3 – Pressure Bar System

TREMCO

Follow the wall manufacturer's recommendations on their method of completing the glazing and sealing of these components.

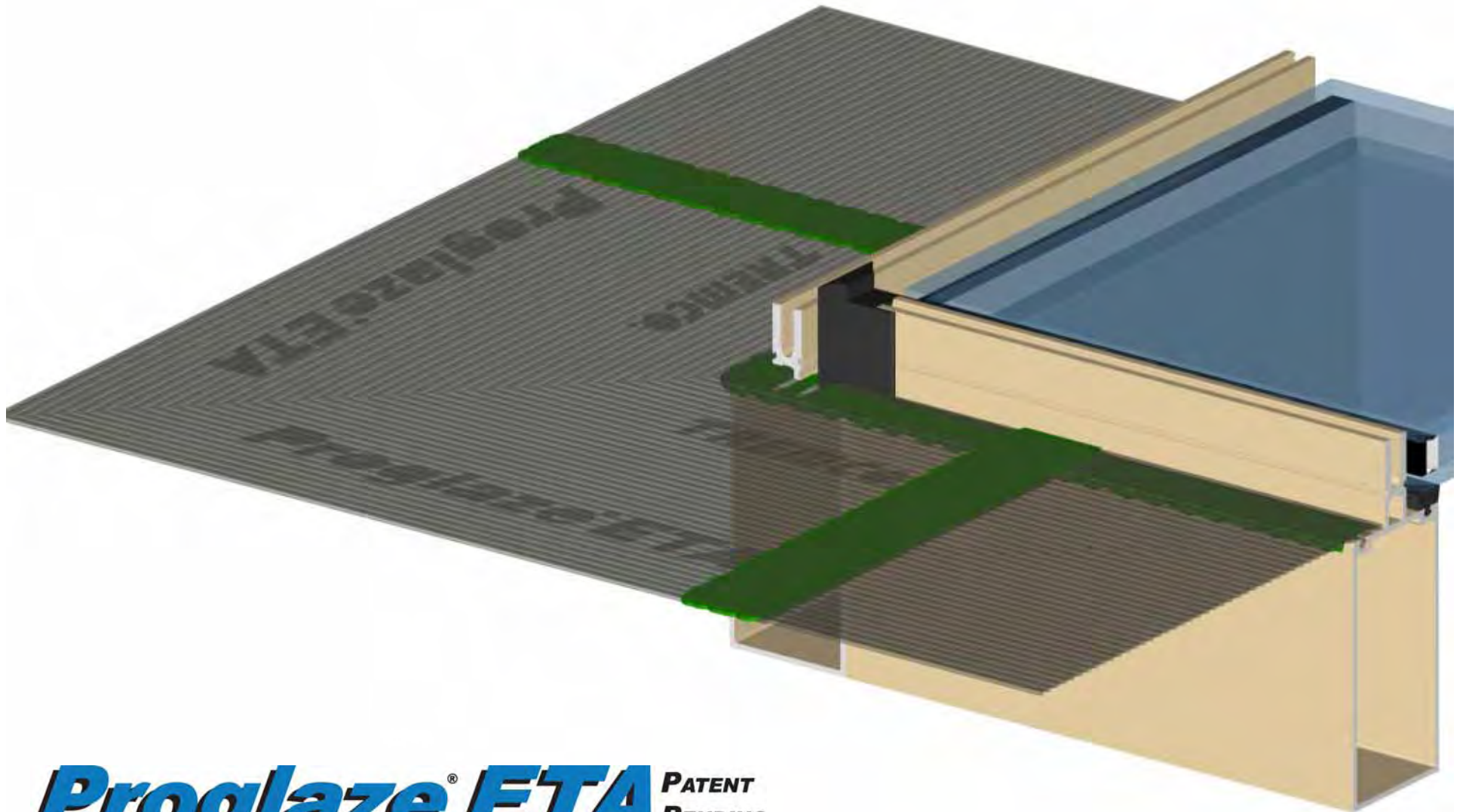

Proglaze[®] ETA PATENT
PENDING
System 3 – Pressure Bar System

TREMCO

Follow the wall manufacturer's recommendations on their method of completing the glazing and sealing of these components.

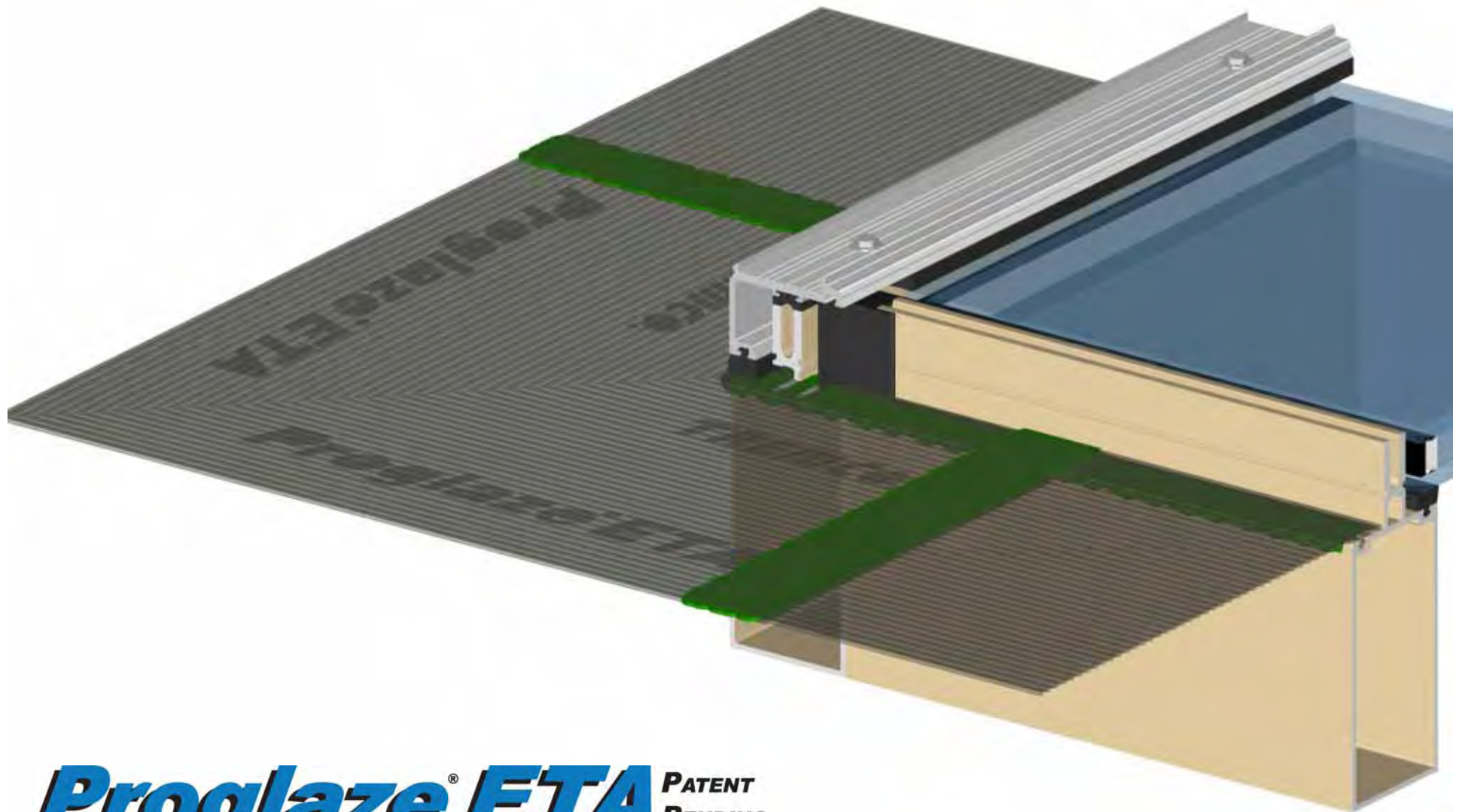

Proglaze[®] ETA PATENT
PENDING
System 3 – Pressure Bar System

TREMCO

Care must be taken not to leave excessive sealant, which may cause uneven glazing pressures and may result in the pressure plate to rotate out of position.

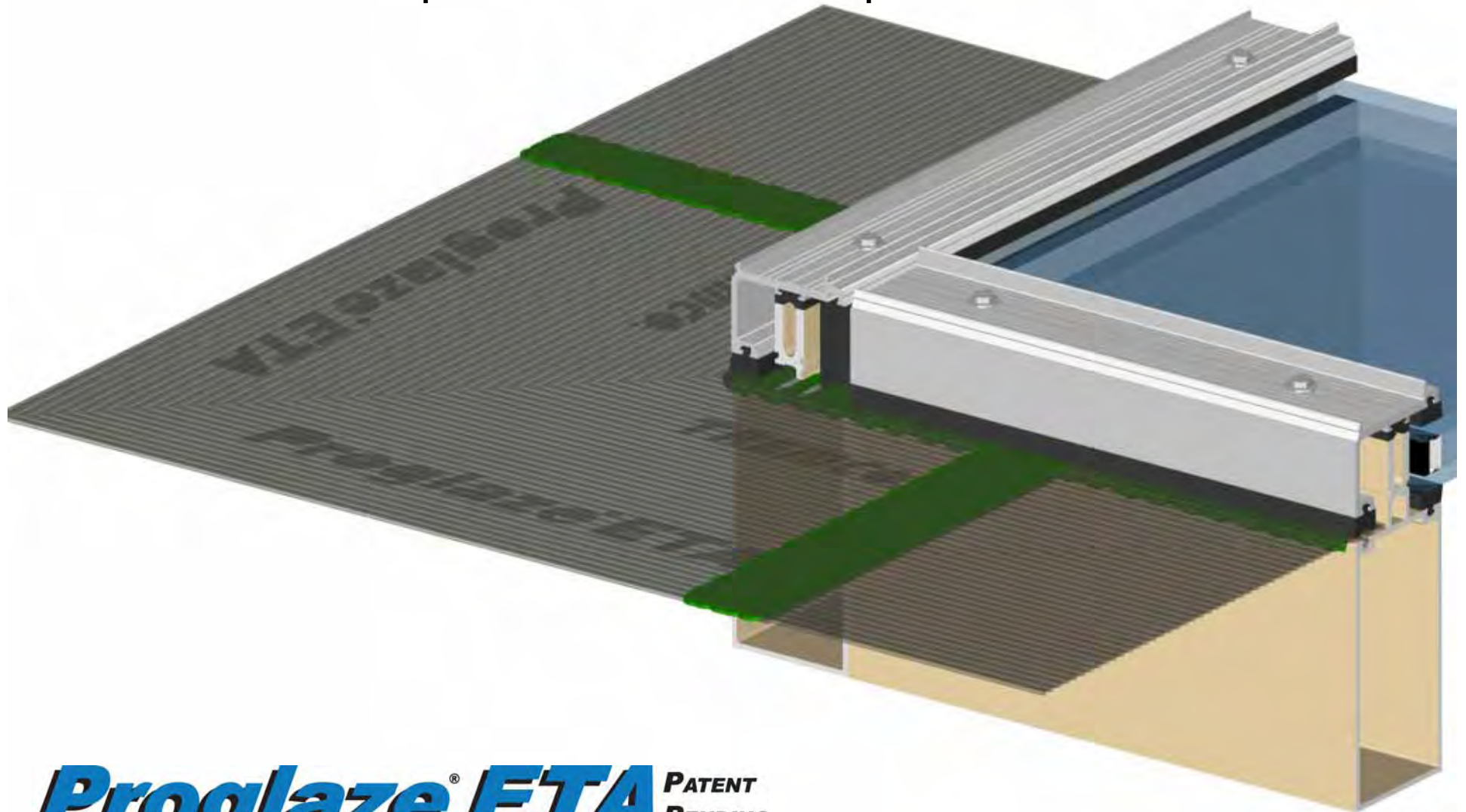

Proglaze[®] ETA PATENT
PENDING
System 3 – Pressure Bar System

TREMCO

Follow the wall manufacturer's recommendations on their method of completing the glazing and sealing of these components.

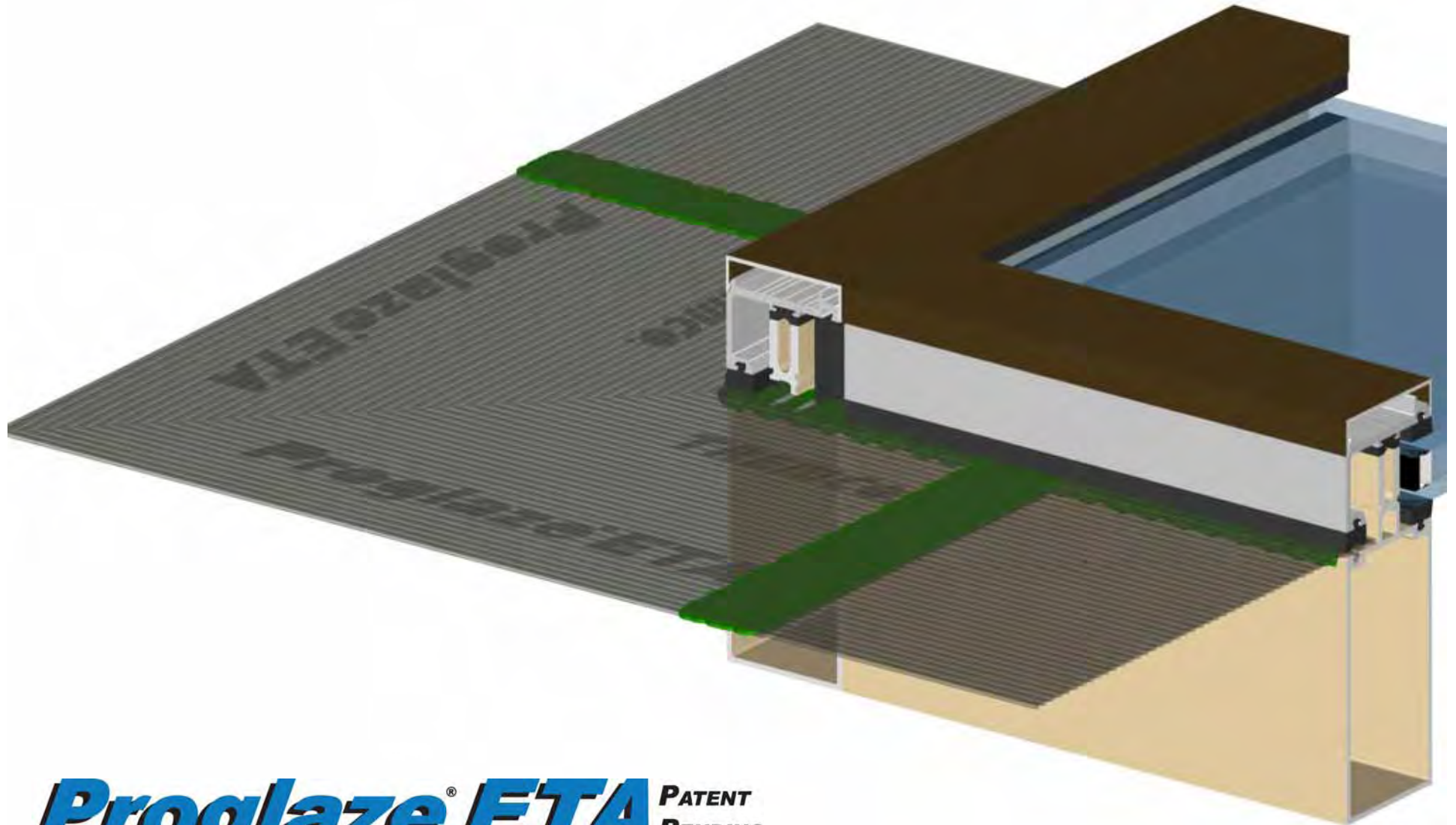

Proglaze[®] ETA PATENT
PENDING
System 3 – Pressure Bar System

TREMCO

Each wall manufacturer will have their own method of sealing the end of their mullion with some type of end cap.

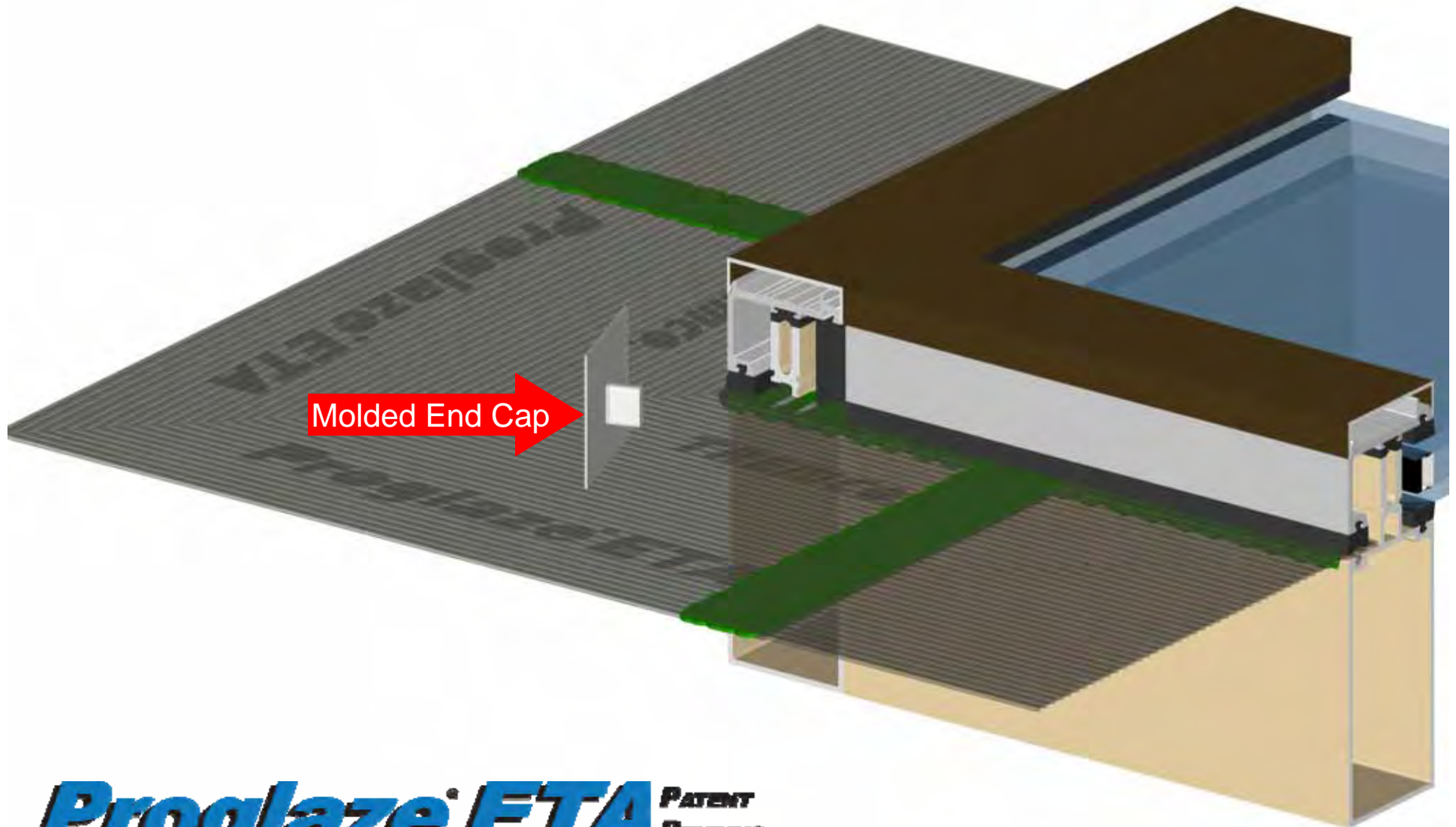

Proglaze[®] ETA PATENT
PENDING
System 3 – Pressure Bar System

TREMCO.

These may need to be modified by trimming to allow the silicone molded corner to by-pass. Follow manufacturer's procedures on how to position and seal these end caps.

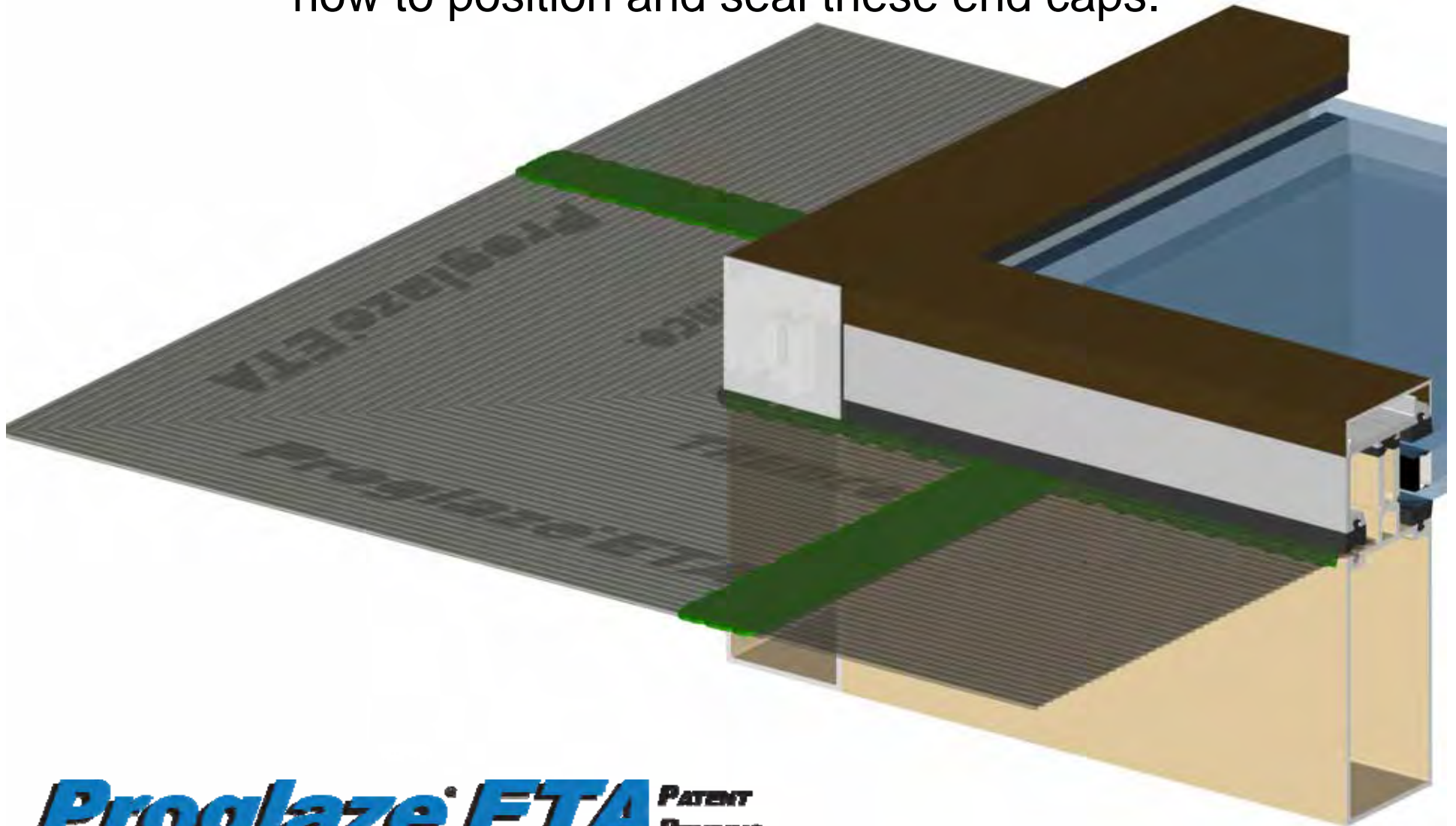

Proglaze[®] ETA PATENT
PENDING
System 3 – Pressure Bar System

TREMCO.