

System No. W-L-5204

August 2008

F Ratings — 1 and 2 Hr (See Item 1)

T Ratings — 1 and 1-1/2 Hr (See Item 1)
(UL/cUL)

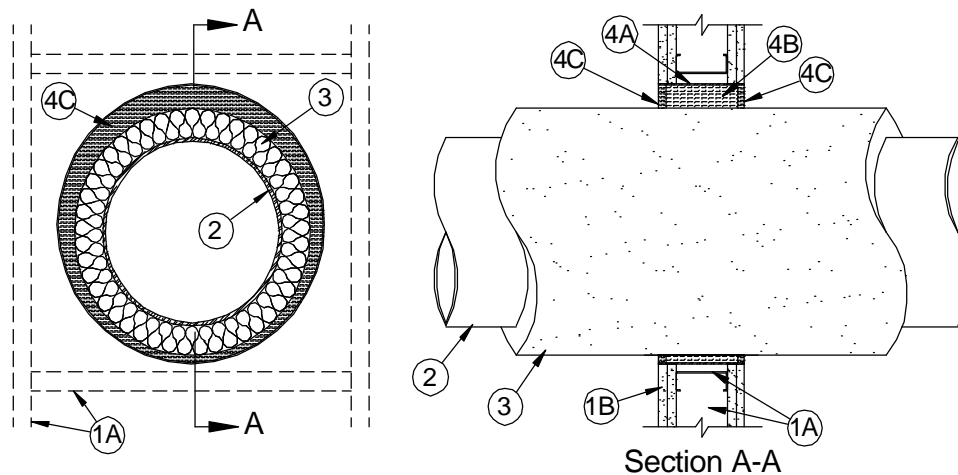

1. **Wall Assembly** — The 1 or 2 hr fire-rated gypsum board/steel stud wall assembly shall be constructed of the materials and in the manner described in the individual U400 or V400 Series Wall or Partition Design in the UL Fire Resistance Directory and shall include the following construction features:

- A. **Studs** — Wall framing to consist of min 3-5/8 in. wide steel channel studs spaced max 24 in. OC. When the outside diam of the insulated pipe is greater than 18 in., the opening shall be framed on all sides using lengths of steel runner channel and steel stud. The framing opening in the wall shall be min 2 in. wider and higher than the outside diam of the insulated pipe such that, when the insulated pipe is centered in the framing opening, a min clearance of 1 in. is present between the insulated pipe and the framing on all four sides.
- B. **Gypsum Board*** — 5/8 in. thick, 4 ft wide with square or tapered edges. The gypsum board type, thickness, number of layers, fastener type and sheet orientation shall be as specified in the individual design in the UL Fire Resistance Directory. Circular cutout in wall to be min 1 in. larger than outside diam of insulated pipe. Max diam of opening is 30 in.

The F Rating of the firestop system is equal to the hourly fire rating of the wall assembly in which it is installed. The T Rating of the firestop system is 1 hr and 1-1/2 hr when installed in 1 hr and 2 hr fire rated walls, respectively.

2. **Pipe** — Nom 24 in. diameter (or smaller) cast iron, ductile iron or Schedule 10 (or heavier) steel pipe. One pipe to be installed either concentrically or eccentrically within the firestop system. Pipe to be rigidly supported on both sides of wall assembly.
3. **Pipe Covering*** — Nom 2 in. thick hollow cylindrical heavy density (min 3.5 pcf) glass fiber units jacketed on the outside with an all service jacket. Longitudinal joints sealed with metal fasteners or factory-applied self-sealing lap tape. Transverse joints secured with metal fasteners or with butt tape supplied with the product. The annular space within the firestop system shall be min 1/4 in. to max 1-1/2 in.

See **Pipe and Equipment Covering — Materials** (BRGU) category in the Building Materials Directory for names of manufacturers. Any pipe covering material meeting the above specifications and bearing the UL Classification Marking with a Flame Spread Index of 25 or less and a Smoke Developed Index of 50 or less may be used.

4. **Firestop System** — The firestop system shall consist of the following:
 - A. **Steel Sleeve** — Cylindrical sleeve fabricated from min 0.056 in. thick (16 ga) galv steel and having a min 2 in. lap along the longitudinal seam. Sleeve installed by coiling the sheet steel to a diam smaller than the through openings, inserting the coil through the openings, and releasing the coil to let it uncoil against the circular cutouts in the gypsum board layers. Ends of sleeve to be flush with or recessed max 1/8 in. from wall surfaces.

- B. **Packing Material** — Min 3-3/4 in. or 5-1/8 in. thickness of min 4 pcf density mineral wool batt insulation firmly-packed into steel sleeve as a permanent form for 1 hr and 2 hr fire rated walls, respectively. Packing material to be recessed from both surfaces of wall as required to accommodate the required thickness of fill material.
- C. **Fill, Void or Cavity Material* — Caulk** — Min 1/2 in. thickness of fill material applied within the annulus, flush with both surfaces of wall. Edges of steel sleeve to be covered with caulk such that no gaps are present between the steel sleeve and the cutouts in the gypsum board.

TREMCO INC — TREMstop Intumescent Acrylic, FyreCaulk, or TREMstop IA+

*Bearing the UL Classification Mark



Reprinted from the Online Certifications Directory with permission from Underwriters Laboratories Inc.
Copyright © 2008 Underwriters Laboratories Inc. ®

Tremco Commercial Sealants & Waterproofing

3735 Green Road, Beachwood, OH 44122 // Phone: 216.292.5000 // 800.321.7906
220 Wicksteed Avenue, Toronto, ON M4H 1G7 // Phone: 416.421.3300 // 800.363.3213
1451 Jacobson Avenue, Ashland OH 44805 // Phone: 419.289.2050 // 800.321.6357