

## Design No. TL/JS 120-04

(Formerly Design CEJ 198P)

February 26, 2003

PERIMETER FIRE BARRIER SYSTEM

T-Rating - 1-1/2 hr.

F-Rating - 2 hr

L-Rating NA

Rated for ± 15% movement

(Intertek)

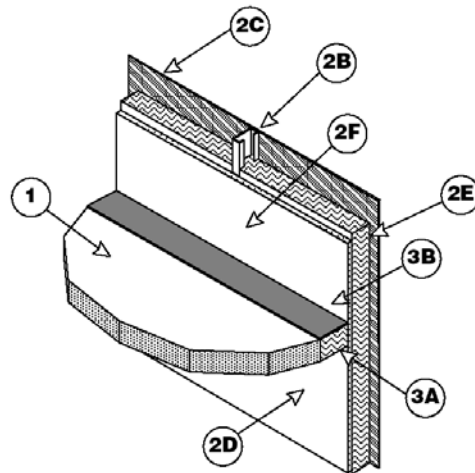

1. **CONCRETE FLOOR ASSEMBLY:** Two-hour rated concrete floor assembly made from either lightweight or normal weight concrete with a density of 100-150 pcf, with a min. thickness of 4-1/2-in. at the joint face. Overall slab thickness may vary to accommodate various blockout depths (longitudinal recesses) formed in the concrete, to house the architectural cover plate. The blockout width may also vary without restriction.
2. **CURTAIN WALL ASSEMBLY:** The curtain wall assembly shall incorporate the following construction features:
  - A. **Mounting Attachment:** (Not shown) Attachment of the curtain wall framing to the structural framing shall be according to the curtain wall manufacturer's instructions. When required, the mounting attachments to the floor slab shall be connected to the joint face of the floor slab, according to the curtain wall manufacturer's instructions. Max. distance between mounting attachments shall be 10 feet.
  - B. **Steel-Stud Framing:** Vertical framing members shall be a min. 3-5/8 in. by 1-1/4 in., 18 GA steel "C" studs. Attachment shall be according to the curtain wall system manufacturer's guidelines. Vertical framing shall not according to the curtain wall system manufacturer's guidelines.
  - C. **Steel Panels:** Steel panels shall be installed to curtain wall framing according to the curtain wall system manufacturer's guidelines or using self-tapping 1-in. pan head framing screws, spaced nominally 8 in. o.c.. Use a min. 20 GA sheet steel panel with max. dimensions of 48 in. by 144 in.
  - D. **Impaling Pins:** (Not shown) When curtain wall insulation is used, use impaling pins when required by manufacturer's instructions. The pins shall be located, sized and installed according to the curtain wall system manufacturer's guidelines.
  - E. **Curtain Wall Insulation:** (Optional) Mineral wool or fiberglass batt insulation\*\* may be used. (\*\* Listed with Omega Point Laboratories) When curtain wall insulation is used, the perimeter joint treatment must be installed before the insulation. Insulation may be butted to top and bottom of perimeter joint treatment but not deform the perimeter joint treatment.
  - F. **Interior Curtain Wall Surface:** Framing covered with one layer of 5/8 in. thick, Type X gypsum wallboard on interior face. The face layer of gypsum wallboard fastened to steel studs with min. #6 1-1/8 in. long bugle-head Phillips drywall screws spaced 12 in. o.c. Joint Tape and Compound - vinyl or casein, dry or premixed joint compound applied to face layers of gypsum wallboard in two coats to all exposed screw heads and gypsum wallboard joints. A min. 2-in. wide paper, plastic or fiberglass tape embedded in first layer of compound over joints in gypsum wallboard. A min. wall cavity depth of 3- 5/8 in. created from unexposed side of gypsum wallboard to unexposed side of panel. The joint face of the curtain wall covered as shown with one layer of gypsum wallboard.

3. **PERIMETER JOINT PROTECTION:** The perimeter joint (linear opening) shall not exceed an 8 in. nom. joint width (joint width at installation) and the perimeter joint treatment shall incorporate the following construction features:
- A. **Packing Material:** Use a min. 4 in. thick, 4 pcf density, mineral wool batt insulation\*\* installed with the fibers running parallel to the slab edge and curtain wall. (\*\* listed with Omega Point Laboratories) The packing material shall be compressed 50% in the nominal joint width. Compress the batt insulation into the perimeter joint such that the top surface of the batt insulation is flush with the top surface of the concrete floor slab. Splices (butt joints) in the lengths of mineral wool batt insulation are to be tightly compressed together. Reference the Introduction to Fire Resistive Joint Systems Section of this Directory for more details on how to determine the cut width of the insulation to be installed in the nominal joint width, and how to determine the compressed percentage of a known insulation width installed in a known nominal joint width.
  - B. **Fill, Void or Cavity Material:** Liquid is to be applied, (sprayed, brushed, or painted) to cover the exposed surface of the mineral wool installed in the perimeter joint. Apply a min. dry wet thickness of 1/8 in. (1/16 in dry film) and overlap the material a min. 1/2 in. onto the adjacent curtain wall assembly and concrete floor slab assembly. If the spraying process is stopped and the applied liquid cures to an elastomeric film before process is restarted, then overlap the edge of the cured material at least 1/8 in. with the spray. Reference Product Section of this Directory for more details about the Listed product.

Listed Manufacturer: TREMCO, Inc. - - Joint Sealant Spray: TREMstop Acrylic-SP

Cycling: Before testing, the spliced, test specimen was cycled 500 times at 30 cpm in accordance with ICBO ES AC 30 (Jan. 1997) and ASTM E 1966.



Reproduced courtesy of Intertek Testing Services. Copyright © 2008 Intertek Testing Services Inc.