

System No. HW-D-0591

September 1, 2009

Assembly Rating — 4 Hr

Nominal Joint Width — 2 in.

L Rating at Ambient — Less than 1 CFM/Lin. Ft.

L Rating at 400 F — Less than 1 CFM/Lin Ft.

Class II Movement Capabilities — 12.5% Compression and Extension
(UL/cUL)

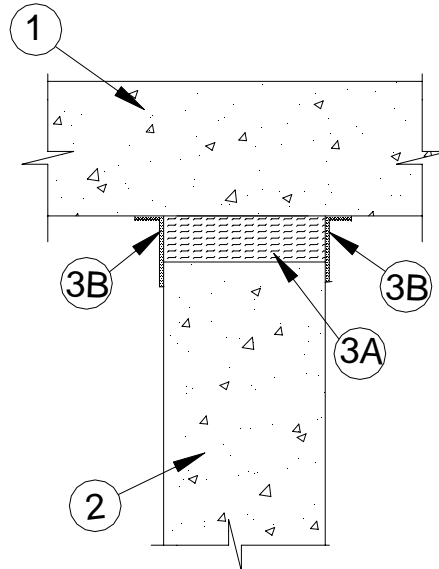

1. Floor Assembly — Min 5-1/2 in. (140 mm) thick reinforced lightweight or normal weight (100-150 pcf or 1600-2400 kg/m³) structural concrete.
 2. Wall Assembly — Min 5-1/2 in. (140 mm) thick reinforced lightweight or normal weight (100-150 pcf or 1600-2400 kg/m³) structural concrete. Wall may also be constructed of any UL Classified Concrete Blocks*.
- See Concrete Blocks (CAZT) category in the Fire Resistance Directory for names of manufacturers.
3. Joint System — Max width of joint (at time of installation of joint system) is 2 in. (51 mm). The joint system is designed to accommodate a max 12.5 percent compression or extension from its installed width. The joint system shall consist of forming and fill materials, as follows:

- A. Forming Material* — Min 4 pcf (64 kg/m³) mineral wool batt insulation installed in joint opening as a permanent form. Pieces of batt cut to min 5-1/2 in. (140 mm) width and installed edge-first into joint opening, parallel with joint direction, such that batt sections are compressed min 50 percent in thickness and such that the compressed batt sections are installed flush with both wall surfaces. Adjoining lengths of batt to be tightly butted with butted seams spaced min 36 in. (914 mm) apart along the length of the joint.

FIBREX INSULATIONS INC — FBX Safing Insulation

ROCK WOOL MANUFACTURING CO — Delta Safing Board

THERMAFIBER INC — SAF Mineral Wool

- B. Fill, Void or Cavity Material* - Sealant — Min 1/8 in. (3 mm) wet thickness (1/16 in. or 2 mm dry thickness) of fill material applied to completely cover surface of mineral wool and lap 1 in. (25 mm) onto each edge of concrete at both surfaces of wall.

TREMCO INC — TREMstop Acrylic SP

*Bearing the UL Classification Mark



Reprinted from the Online Certifications Directory with permission from Underwriters Laboratories Inc.
Copyright © 2008 Underwriters Laboratories Inc. ®

Tremco Commercial Sealants & Waterproofing

3735 Green Road, Beachwood, OH 44122 // Phone: 216.292.5000 // 800.321.7906

220 Wicksteed Avenue, Toronto, ON M4H 1G7 // Phone: 416.421.3300 // 800.363.3213

1451 Jacobson Avenue, Ashland OH 44805 // Phone: 419.289.2050 // 800.321.6357