

System No. HW-D-0330

February 27, 2004

Assembly Rating - 2 Hr

Nominal Joint Width - 1 In.

Class II Movement Capabilities - 18.75% Compression or Extension

(UL/cUL)

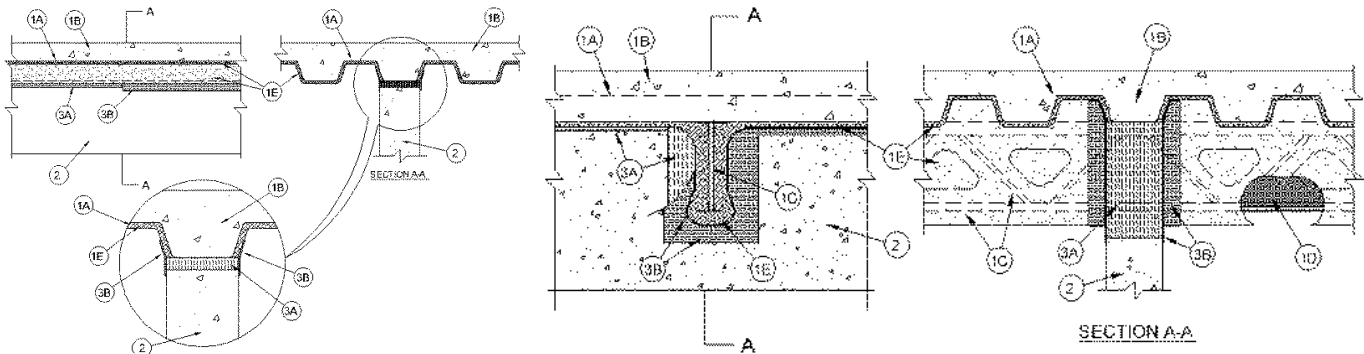

- Floor Assembly** – The fire-rated fluted steel deck/concrete floor assembly shall be constructed of the materials and in the manner described in the individual D700 Series Floor-Ceiling Design in the UL Fire Resistance Directory and shall include the following construction features:
 - Steel Floor and Floor Units*** – Max 3 in. (76 mm) deep galv steel fluted floor units.
 - Concrete** – Min 2-1/2 in. (64 mm) thick reinforced concrete, as measured from the top plane of the floor units.
 - Structural Steel Support** – (Optional) - Steel beam or open-web steel joist, as specified in the individual D700 Series Floor-Ceiling Design, used to support steel floor units. Structural steel support oriented perpendicular to wall assembly.
 - Steel Lath** – Where open-web steel joists pass through the fire rated wall, 3/8 in. (10 mm) diamond mesh expanded steel lath having a nom weight of 1.7 to 3.4 lb per sq yd (922 to 1840 g/sq meter) shall be secured to one side of each joist with steel tie wire and the lath shall be fully covered with spray applied fire resistive material with no min thickness requirement.
 - Spray-Applied Fire Resistive Material*** – Steel floor units and structural steel supports to be sprayed with the thickness of material specified in the individual D700 Series Design. The spray applied fire resistive material is mixed with water in accordance with the mixing instructions on the bag and is sprayed onto steel deck and structural steel support. Material to be excluded from the valleys of the steel floor units immediately above the wall.

W R GRACE & CO - CONN
CONSTRUCTION PRODUCTS DIV – Type MK-6/HY
- Wall Assembly** – Min 6 in. (152 mm) thick reinforced lightweight or normal weight (100-150 pcf (1600-2400 kg / cu m)) structural concrete. Wall to be parallel to and centered under the valleys of the steel floor units. A max 1 in. (25 mm) gap shall be maintained between the top of the wall and the bottom plane of the steel floor units with an equivalent or greater gap between the top edge of the wall and the spray applied fire resistive material on the structural steel support member. A min clearance of 1 in. (25 mm) to a maximum clearance of 3-1/8 in. (79 mm) shall be maintained between the framed opening and the spray applied fire resistive material on the two sides of the structural support member. Wall may also be constructed of any UL Classified **Concrete Blocks***.

See **Concrete Blocks*** (CAZT) category in the Fire Resistance Directory for names of manufacturers.
- Joint System** – Max separation between bottom plane of steel floor unit and top of concrete wall (at time of installation of joint system) is 1 in. (25 mm). Max separation between spray applied fire resistive material on bottom of structural support member and framed opening in top of wall is 1-1/2 in. (38 mm). The joint system is designed to accommodate a max 18.75 percent compression or extension from it's installed width as measured between bottom plane of steel floor unit and top of concrete wall. The joint system shall consist of forming and fill materials, as follows:
 - Forming Material*** – Nom 4 in. (102 mm) thick, 4 pcf (64 kg/cu meter) mineral wool batt insulation cut to a U-shape with the overall height and width equal to the notched opening in the wall. Width of legs of the U-shaped piece shall be sufficient to attain a min compression of 50 percent between the sides of the protected structural member and the framed opening. Additional U-shaped piece of nom 2 in. (51 mm) thick forming material similarly cut and tightly packed around the protected structural member so that the forming material is flush with both surfaces of the wall. The thickness of bottom of U-shaped forming material shall be sufficient to attain a min compression of 50 percent between the bottom of the

framed opening and the bottom of the protected structural steel member. Two additional rectangular shaped sections of mineral wool batt insulation, one nom 4 in. (102 mm) thick and one nom 2 in. (51 mm) thick, are compressed 50 percent in width and installed to completely fill the gap between the top of the wall and the bottom of the protected/unprotected floor deck. The forming material shall be installed flush with both surfaces of wall.

FIBREX INSULATIONS INC – FBX Safing Insulation

ROCK WOOL MANUFACTURING CO – Delta Safing Board

- B. **Fill, Void or Cavity Material* - Sealant** – Min 1/8 in. (3 mm) wet thickness of fill material spray applied over the forming material on each side of the wall. Fill material to overlap a min of 1 in. (25 mm) onto the concrete wall and a min 2 in. (51 mm) onto the spray applied material (Item 1C) on the steel floor unit and on the structural steel support member on both sides of wall.

TREMCO INC – TREMstop Acrylic-SP

*Bearing the UL Classification Mark



Reprinted from the Online Certifications Directory with permission from Underwriters Laboratories Inc.
Copyright © 2008 Underwriters Laboratories Inc. ®

Tremco Commercial Sealants & Waterproofing

3735 Green Road, Beachwood, OH 44122 // Phone: 216.292.5000 // 800.321.7906
220 Wicksteed Avenue, Toronto, ON M4H 1G7 // Phone: 416.421.3300 // 800.363.3213
1451 Jacobson Avenue, Ashland OH 44805 // Phone: 419.289.2050 // 800.321.6357