

System No. FF-D-1060

December 01, 2003

Assembly Rating - 4 Hr

L Rating at Ambient - Less than 1 CFM/Lin Ft

L Rating at 400° F - Less than 1 CFM/Lin Ft

Nominal Joint Width - 3 In

Class II Movement Capabilities - 12.5% Extension or Compression
(UL/cUL)

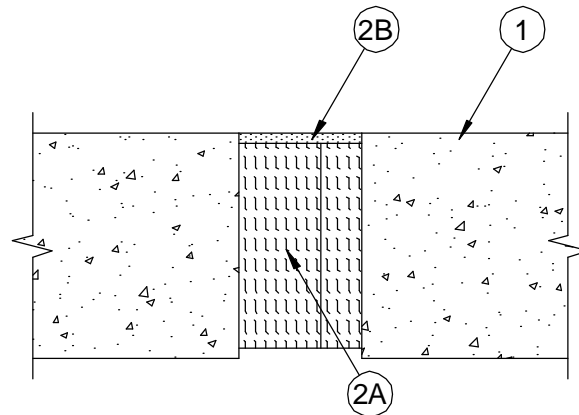

1. **Floor Assembly** — Min 5-1/2 in. (140 mm) thick reinforced lightweight or normal weight (100-150 pcf (1600-2400 kg/cu meter)) structural concrete.
2. **Joint System** — **Max width of joint (at time of installation of joint) is 3 in. (76 mm).** The joint system is designed to accommodate a max 12.5 percent compression or extension from it's installed width. The joint system shall consist of the following:
 - A. **Forming Material*** — Min 4.0 pcf (64 kg/cu meter) mineral wool batt insulation installed in joint opening as a permanent form. Pieces of batt cut to min width of 5 in. (127 mm) and installed edge-first into joint opening, parallel with joint direction, such that batt sections are compressed min 50 percent in thickness and such that the compressed batt sections are recessed from top surface of floor to accommodate the required thickness of fill material. Adjoining lengths of batt to be tightly-butted with butted seams spaced min 36 in. (914 mm) apart along the length of the joint.

FIBREX INSULATIONS INC — FBX Safing Insulation.
ROCK WOOL MANUFACTURING CO — Delta Safing Board
 - B. **Fill, Void or Cavity Material* — (Caulk)** — Min 1/4 in. (6 mm) thickness of fill material applied within the joint, flush with top surface of floor.

TREMCO INC — Fyre-Sil.

*Bearing the UL Classification Mark



Reprinted from the Online Certifications Directory with permission from Underwriters Laboratories Inc.
Copyright © 2008 Underwriters Laboratories Inc. ®